



Split Tip klima uređaj

# KORISNIČKI PRIRUČNIK

**BROJ MODELA:**  
CB1-09HRFN8-I  
CB1-12HRFN8-I



**MSmartHome**  
Preuzmite aplikaciju i aktivirajte proizvod

Upozorenja: Prije uporabe ovog proizvoda pažljivo pročitajte ovaj priručnik i sačuvajte ga za buduću upotrebu. Radi poboljšanja proizvoda, dizajn i specifikacije podložni su promjenama bez prethodne najave. Za pojediniosti se obratite svom prodavaču ili proizvođaču. Gornji dijagram je samo za referencu. Kao referencu uzmite izgled stvarnog proizvoda

# PISMO ZAHVALE

Hvala što ste odabrali Mideu! Prije korištenja vašeg novog Midea proizvoda, molimo vas da temeljito pročitate ovaj priručnik kako biste bili sigurni da znate kako na siguran način rukovati značajkama i funkcijama koje nudi vaš novi uređaj.





## SADRŽAJ

<b>PISMO ZAHVALE</b> .....	01
<b>SIGURNOSNE MJERE OPREZA</b> .....	02
<b>SPECIFIKACIJE</b> .....	06
<b>PREGLED PROIZVODA</b> .....	07
<b>INSTALACIJA PROIZVODA</b> .....	08
Instalacija unutarnje jedinice .....	10
Instalacija vanjske jedinice .....	20
Priključak cijevi rashladnog sredstva.....	25
Izbacivanje zraka .....	29
Provjere elektrike i curenja plina .....	31
Probni rad .....	32
Pakiranje i raspakiranje jedinice .....	33
<b>UPUTE ZA UPORABU</b> .....	34
Zaslon unutarnje jedinice .....	34
Uporaba daljinskog upravljača.....	39
Podешavanje i uporaba aplikacije.....	50
<b>BRIGA I ODRŽAVANJE</b> .....	56
<b>RJEŠAVANJE PROBLEMA</b> .....	58
<b>TRŽIŠNI ZNAKOVI, PRAVA KOPIRANJA I PRAVNE NAPOMENE</b> ...	61
<b>ZBRINJAVANJE I RECIKLIRANJE</b> .....	61
<b>NAPOMENA O ZAŠTITI PODATAKA</b> .....	62

# SIGURNOSNE MJERE OPREZA

Vrlo je važno da prije uporabe i instalacije pročitate sigurnosne mjere opreza. Neispravna instalacija može uzrokovati ozbiljnu štetu ili ozljede.

## Objašnjenje simbola

	<b>Upozorenje na električni napon</b> Ovaj simbol označava da postoji opasnost po život i zdravlje ljudi zbog napona.
	<b>Upozorenje</b> Signalna riječ označava opasnost srednjeg stupnja rizika <b>koji, ako se ne izbjegne, može dovesti do smrti ili ozbiljnih ozljeda.</b>
	<b>Oprez</b> Signalna riječ označava opasnost s niskim stupnjem rizika koja, ako se ne izbjegne, može rezultirati lakšim ili srednje teškim ozljedama.
	<b>Pažnja</b> Signalna riječ označava važne informacije (npr. oštećenje imovine), ali ne i opasnost.
	<b>Pridržavajte se uputa</b> Ovaj simbol označava da serviser smije rukovati i održavati ovaj uređaj samo u skladu s uputama za uporabu.

Pažljivo i pozorno pročitatajte ove upute za uporabu prije uporabe/puštanja uređaja u rad i čuvajte ih u neposrednoj blizini mjesta postavljanja ili uređaja za kasniju uporabu!

## UPOZORENJE

Ovaj uređaj mogu koristiti djeca starija od 8 godina i osobe sa smanjenim fizičkim, osjetilnim ili mentalnim sposobnostima ili nedostatkom iskustva i znanja, ako su pod nadzorom ili su dobili upute u svezi s korištenjem uređaja na siguran način i razumiju uključene opasnosti. Djeca se ne smiju igrati s uređajem. Čišćenje i vlastito održavanje ne smiju obavljati djeca bez nadzora (zemlje Europske unije).

Ovaj uređaj nije namijenjen za korištenje od strane osoba (uključujući djecu) sa smanjenim fizičkim, osjetilnim ili mentalnim sposobnostima, ili nedostatkom iskustva i znanja, osim ako nisu pod nadzorom ili su dobili upute o korištenju uređaja od strane osobe odgovorne za njihovu sigurnost. Djecu treba nadzirati kako bi se osiguralo da se ne igraju s uređajem.

## **⚠ UPOZORENJE ZA UPORABU PROIZVODA**

- Ako dođe do neuobičajene situacije (kao što je miris paljevine), odmah isključite jedinicu i odspojite napajanje. Nazovite svog prodavača za upute kako biste izbjegli strujni udar, požar ili ozljede.
- Nemojte gurati prste, šipke ili druge predmete u ulaz ili izlaz zraka. To može uzrokovati ozljede jer se ventilator može vrtjeti velikom brzinom.
- Nemojte koristiti zapaljive sprejeve poput spreja za kosu, laka ili boje u blizini jedinice. To može uzrokovati požar ili izgaranje.
- Nemojte koristiti klima uređaj na mjestima blizu ili oko zapaljivih plinova. Emitirani plin može se nakupiti oko jedinice i izazvati eksploziju.
- Nemojte koristiti klima uređaj u mokroj prostoriji kao što je kupaonica ili praonica rublja. Previše izlaganja vodi može uzrokovati kratki spoj električnih komponenti.
- Ne izlažite svoje tijelo direktnom hladnom zraku dulje vrijeme.
- Ne dopustite djeci da se igraju s klima uređajem. Djeca moraju cijelo vrijeme biti pod nadzorom u blizini jedinice.
- Ako se klima uređaj koristi zajedno s plamenicima ili drugim uređajima za grijanje, temeljito prozračite prostoriju kako biste izbjegli nedostatak kisika.
- U određenim funkcionalnim okruženjima, kao što su kuhinje, poslužiteljske sobe itd., preporučuje se korištenje posebno dizajniranih klimatizacijskih jedinica.

## **⚠ ELEKTRIČNA UPOZORENJA**

- Koristite samo specificirani kabel za napajanje. Ako je kabel za napajanje oštećen, mora ga zamijeniti proizvođač, njegov serviser ili slično kvalificirana osoba kako bi se izbjegla opasnost.
- Proizvod u trenutku postavljanja mora biti propisno uzemljen, inače može doći do strujnog udara.
- Za sve električne radove poštujujte sve lokalne i nacionalne standarde ožičenja, propise i priručnik za instalaciju. Čvrsto spojite kabele i čvrsto ih stegnite kako biste spriječili da vanjske sile oštete priključak. Nepravilni električni spojevi mogu se pregrijati i uzrokovati požar, a mogu uzrokovati i strujni udar. Sve električne veze moraju biti izvedene prema dijagramu električnog ožičenja koji se nalazi na pločama unutarnje i vanjske jedinice.
- Sva ožičenja moraju biti pravilno postavljena kako bi se osiguralo da se poklopac upravljačke ploče može ispravno zatvoriti. Ako poklopac upravljačke ploče nije pravilno zatvoren, može doći do korozije i uzrokovati zagrijavanje priključnih točaka na priključku, zapaljenje ili uzrokovati strujni udar.
- Isključivanje mora biti ugrađeno u fiksno ožičenje u skladu s pravilima za ožičenje.
- Nemojte povlačiti kabel za napajanje kako biste isključili jedinicu. Čvrsto držite utikač i izvucite ga iz utičnice. Direktno povlačenje kabela može ga oštetiti, što može dovesti do požara ili strujnog udara.
- Nemojte mijenjati duljinu kabela za napajanje niti koristiti produžni kabel za napajanje jedinice.
- Ne dijelite električnu utičnicu s drugim uređajima. Nepravilno ili nedovoljno napajanje može uzrokovati požar ili strujni udar.
- Održavajte utikač čistim. Uklonite svu prašinu ili prljavštinu koja se nakuplja na ili oko utikača. Prljavi utikači mogu uzrokovati požar ili električni udar.
- Ako spajate napajanje na fiksno ožičenje, u fiksno ožičenje potrebno je ugraditi uređaj za isključivanje na svim polovima koji ima najmanje 3 mm razmaka na svim polovima i ima struju curenja koja može premašiti 10 mA, uređaj za zaostalu struju (RCD) koji ima nazivnu preostalu radnu struju koja ne prelazi 30 mA, u skladu

spravlilima za ožičenje.

## NAPOMENA O SPECIFIKACIJAMA OSIGURAČA

Tiskana pločica (PCB) klimatizacijskog uređaja dizajnirana je s osiguračem koji osigurava prekostrujnu zaštitu. Specifikacije osigurača ispisane su na tiskanoj ploči, kao što su: T3.15AL/250VAC, T5AL/250VAC, T3.15A/250VAC, T5A/250VAC, T20A/250VAC, T30A/250VAC, itd.

## UV-C lampa (vrijedi samo sa jedinice s UV-C lampom)

- Ovaj uređaj uključuje UV-C lampu. Pročitajte upute za održavanje prije otvaranja uređaja.
- Nemojte koristiti UV-C lampe izvan uređaja.
- Uređaji koji su očito oštećeni ne smiju se koristiti.
- Nenamjenska uporaba uređaja ili oštećenje kućišta može dovesti do izlaska opasnog UV-C zračenja. UV-C zračenje može, čak i u malim dozama, uzrokovati ozljede vida i kože.
- Prije otvaranja vrata i pristupnih ploča koje nose simbol opasnosti ULTRAVIOLET RADIATION za provođenje KORISNIČKOG ODRŽAVANJA, preporuča se isključiti napajanje.
- UV-C lampa se ne može čistiti, popraviti i zamijeniti.
- UV-C BARIJERE sa simbolom opasnosti ULTRAVIOLET RADIATION ne smiju se uklanjati.

### UPOZORENJE

Ovaj uređaj sadrži UV emiter. Nemojte direktno gledati u izvor svjetlosti

### UPOZORENJE ZA INSTALACIJU PROIZVODA

- Instalaciju mora izvršiti ovlašten distributer ili stručnjak. Neispravna instalacija može uzrokovati curenje vode, strujni udar ili požar.
- Instalacija mora biti izvedena prema uputama za montažu. Neispravna instalacija može uzrokovati curenje vode, strujni udar ili požar.
- Obratite se ovlaštenom servisnom tehničaru za popravak ili održavanje ove jedinice. Ovaj uređaj mora biti instaliran u skladu s nacionalnim propisima o ožičenju. Za ugradnju koristite samo priloženi pribor i specificirane dijelove.
- Korištenje nestandardnih dijelova može uzrokovati curenje vode, strujni udar, požar i/ili uzrokovati kvar jedinice.
- Postavite jedinicu na čvrsto mjesto koje može izdržati težinu jedinice. Ako odabrano mjesto ne može podnijeti težinu jedinice ili ako instalacija nije pravilno izvedena, jedinica može pasti i uzrokovati ozbiljne ozljede ili štetu.
- Postavite drenažne cijevi prema uputama u ovom priručniku. Nepravilna drenaža može uzrokovati štetu u vašem domu i imovini.
- Za jedinice koje imaju pomoćni električni grijač, nemojte instalirati jedinicu unutar 1 metra od zapaljivih materijala.
- Ne postavljajte jedinicu na mjesto koje bi moglo biti izloženo curenju zapaljivog plina. Ako se oko jedinice nakupi zapaljivi plin, može izazvati požar.
- Ne uključujte napajanje dok svi radovi nisu dovršeni.
- Samo kvalificirani tehničar može pomaknuti ili premjestiti klima uređaj.
- Za dodatne informacije pročitajte odlomke koji pokrivaju instalaciju unutarnje i

vanjske jedinice.

## **⚠ OPREZ**

- Isključite klima uređaj i isključite struju ako ga nećete koristiti dulje vrijeme.
- Isključite i odspojite uređaj tijekom oluja.
- Provjerite može li kondenzirana voda nesmetano otjecati iz jedinice.
- Nemojte koristiti klima uređaj mokrim rukama. To može uzrokovati električni udar.
- Nemojte koristiti uređaj ni za koju drugu svrhu osim za koju je namijenjen.
- Nemojte se penjati na vanjsku jedinicu niti stavljati predmete na nju.
- Nemojte dopustiti da klima uređaj radi dulje vrijeme s otvorenim vratima ili prozorima ili ako je vlažnost vrlo visoka

## **UPOZORENJA U SVEZI ČIŠĆENJA I ODRŽAVANJA**

- Prije čišćenja isključite uređaj i odspojite ga od napajanja. Ako to ne učinite, može doći do strujnog udara.
- Za čišćenje uređaja možete koristiti vlažnu krpu. Ne smije se prati vodom.
- Ne čistite klima uređaj zapaljivim sredstvima za čišćenje. Zapaljiva sredstva za čišćenje mogu izazvati požar ili deformaciju.

## **Napomena o fluoriranim plinovima (Nije primjenjivo za jedinicu koja koristi R290 rashladno sredstvo)**

- Ova jedinica klima uređaja sadrži fluorirane stakleničke plinove. Za posebne informacije o vrsti plina i količini, molimo pogledajte odgovarajuću naljepnicu na samoj jedinici ili "Korisnički priručnik - Tehnički podaci o proizvodu" u pakiranju vanjske jedinice. (Samo proizvodi iz Europske unije).
- Instalaciju, servis, održavanje i popravak ove jedinice mora izvoditi ovlašteni tehničar.
- Deinstalaciju i recikliranje proizvoda mora izvršiti certificirani tehničar. Za opremu koja sadrži fluorirane stakleničke plinove u ekvivalentnim količinama od 5 tona CO<sub>2</sub> ili više, ali manje od 50 tona CO<sub>2</sub> ekvivalenta, ako sustav ima instaliran sustav za otkrivanje curenja, mora se provjeriti ima li curenja najmanje svaka 24 mjeseca. .
- Kada se jedinica provjerava na curenje, preporučuje se pravilno vođenje evidencije o svim provjerama.

## **⚠ UPOZORENJE KOD UPORABE R32/R290 RASHLADNOG SREDSTVA**

- Kada se koriste zapaljiva rashladna sredstva, uređaji se moraju skladištiti u dobro prozračenom prostoru gdje veličina prostorije odgovara površini prostorije koja je specifična za rad.
- Za modele s R32 rashladnim sredstvom:
- Uređaji se moraju instalirati, koristiti i skladištiti u prostoriji tlocrtna površina veća od 4 m<sup>2</sup>.
- Za modele s R290 rashladnim sredstvom, uređaj se mora instalirati, koristiti i skladištiti u prostoriji čija je podna površina veća od:  
Jedinice ≤2,6kW: 17,33m<sup>2</sup>                      Jedinice >2,6kW i ≤3,5kW: 25,4m<sup>2</sup>  
Jedinice >3,5kW i ≤5,2kW: 34,67m<sup>2</sup>                      Jedinice >5,3kW i ≤7,1kW: 47,33m<sup>2</sup>
- Višekratni mehanički spojevi i rašireni spojevi nisu dopušteni u zatvorenom prostoru

# SPECIFIKACIJE

<b>Model proizvoda</b>	<b>CB1-09HRFN8-I CB1-09HFNX-O</b>	<b>CB1-12HRFN8-I CB1-12HFNX-O</b>
Izvor napajanja	220-240V-50Hz,1Ph	
Kapacitet hlađenja	9500Btu/h	12000Btu/h
Kapacitet grijanja	10000Btu/h	13000Btu/h
Nazivna struja (A)	10.5	10.5
Nazivna ulazna snaga (W)	2200	2200
Rashladno sredstvo (kg)	R32/0.55	R32/0.62
Min. površina prostorije (m <sup>2</sup> )	13	16

# PREGLED PROIZVODA

## ● NAPOMENA O ILUSTRACIJAMA:

Ilustracije u ovom priručniku služe u svrhu objašnjenja. Stvarni oblik vaše unutarnje jedinice može biti malo drugačiji

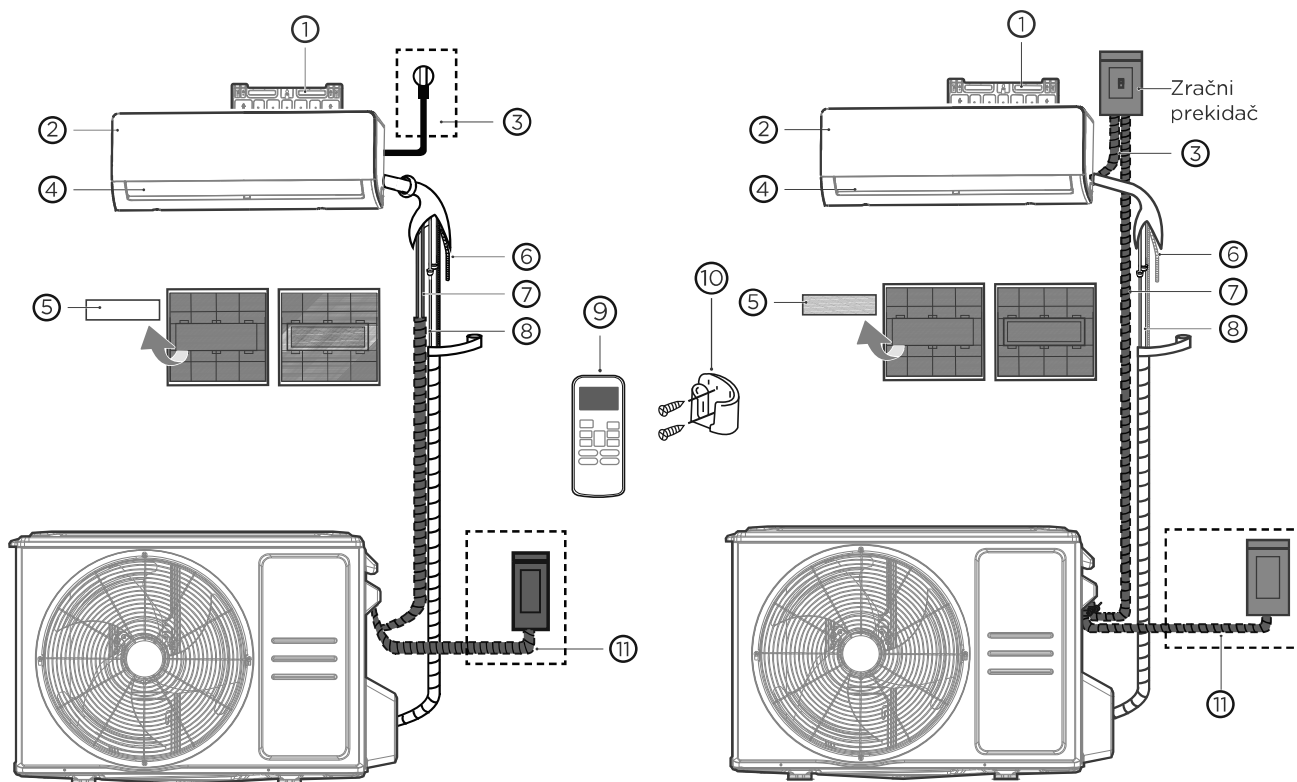

(1)

(2)

- ① Ploča za ugradnju na zid
- ② Prednja ploča
- ③ Kabel napajanje (ne sve jedinice)
- ④ Zaklopka

- ⑤ Funkcijski filter (Iza glavnog filtra - neke jedinice)
- ⑥ Drenažna cijev
- ⑦ Signalni kabel
- ⑧ Cijevi rashladnog sredstva











- ⑨ Daljinski upravljač
- ⑩ Držać daljinskog upravljača (nije dio isporuke)
- ⑪ Kabel za napajanje vanjske jedinice (ne sve jedinice)



# INSTALACIJA PROIZVODA

## Dodaci

Sustav klima uređaja dolazi sa sljedećim dodacima. Koristite sve instalacijske dijelove i pribor za ugradnju klima uređaja. Neispravna instalacija može dovesti do curenja vode, strujnog udara i požara ili uzrokovati kvar opreme. Stavke koje nisu uključene u isporuku klima uređaja moraju se odvojeno kupiti.

Naziv dodatka	Kol (kom)	Oblik	Naziv dodatka	Kol (kom)	Oblik
Priručnik	1-3		Daljinski upravljač	1	
Drenažni spoj (za modele s hlađenjem & grijanjem)	1		Baterija	2	
Brtva (za modele s hlađenjem & grijanjem)	1		Držac daljinskog upravljača (prodaje se odvojeno)	1	
Ploča za ugradnju	1		Vijak za učvršćenje držača daljinskog upravljača (prodaje se odvojeno)	2	
Tipla	5-8(ovisno o modelu)		Mali filter(tijekom instalacije ovlašteni tehničar mora ga ugraditi iza glavnog filtra zraka)	1-2(ovisno o modelu)	
Vijak za učvršćenje ploče za ugradnju	5-8(ovisno o modelu)				

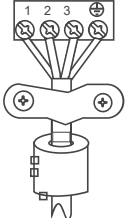
Naziv	Oblik	Količina (kom)	
Sklop spojne cijevi	Strana tekućine	Φ6.35(1/4in)	Spojne cijevi moraju se kupiti odvojeno. Molimo vas obratite se distributeru za pravilnu veličinu za kupljeni uređaj
		Φ9.52(3/8in)	
	Strana plina	Φ9.52(3/8in)	
		Φ12.7(1/2in)	
		Φ16(5/8in)	
	Φ19(3/4in)		
Magnetski prsten i traka(Ne sve jedinice. Gdje je primjenjivo, pogledajte dijagram ožičenja)	 Provucite traku (u paketu s magnetskim prstenom) kroz rupu magnetskog prstena kako bi učvrstili kabel	Ovisno o modelu	

## Potreban alat



Rukavice



Odvijač & ključ



Udarna bušilica

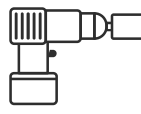

Krunsko svrdlo



Naočale & maska



Vinil

## Sažetak instalacija - unutarnja jedinica

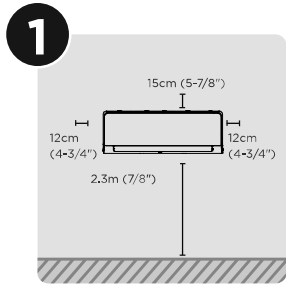

Odabir lokacije instalacije

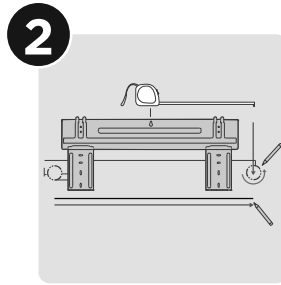

Učvršćenje montažne ploče

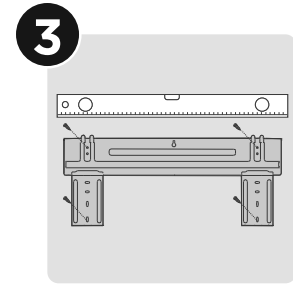

Određivanje pozicije rupa u zidu

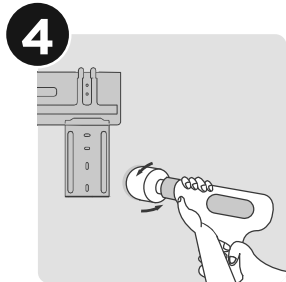

Bušenje rupe u zidu

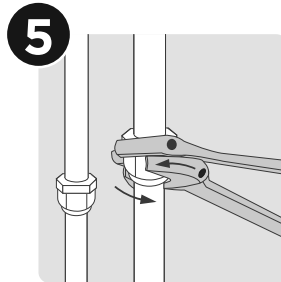

Spajanje cijevi

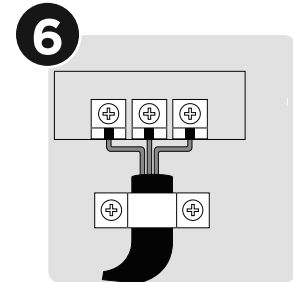

Spajanje ožičenja  
(nije primjenjivo za neke lokacije u Sjevernoj Americi)

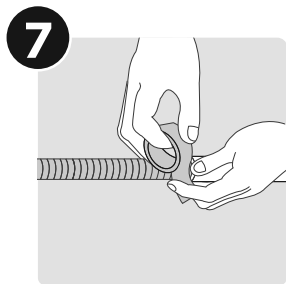

Priprema drenažnog crijeva

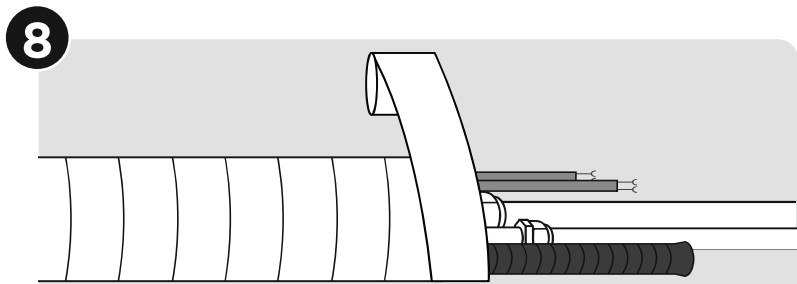

Omatanje cijevi i kabela  
(nije primjenjivo za neke lokacije u Sjevernoj Americi)

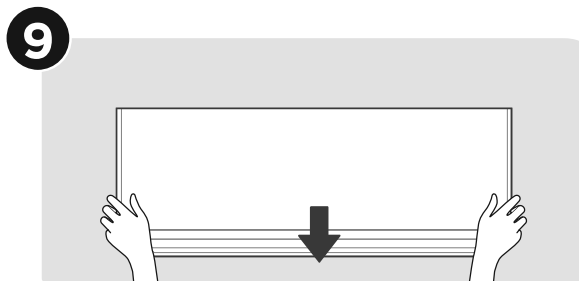

Postavljanje unutarnje jedinice

## Instalacija unutarnje jedinice

### 1 Odabir lokacije instalacije

#### ● **NAPOMENA: Prije instalacije**

Prije instalacije unutarnje jedinice, pogledajte naljepnicu na kutiji proizvoda kako biste bili sigurni da broj modela unutarnje jedinice odgovara broju modela vanjske jedinice.

Slijede standardi koji će vam pomoći da odaberete odgovarajuće mjesto za jedinicu.

#### **Ispravna mjesta ugradnje zadovoljavaju sljedeće standarde:**



Dobra cirkulacija zraka

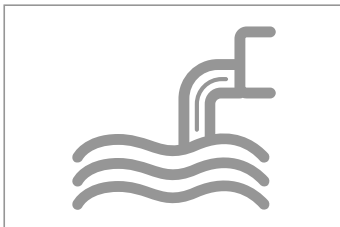

Praktična drenaža



Buka jedinice neće ometati druge ljude

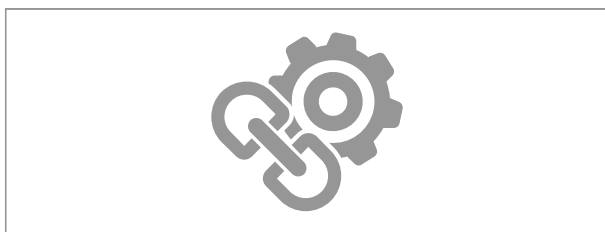

Čvrsta – lokacija neće vibrirati  
 Dovoljno čvrsta za pridržavanje mase jedinice

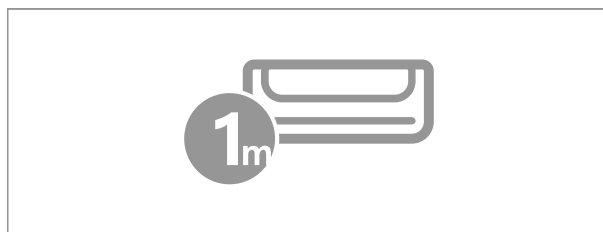

Na lokaciju barem jedan metar dalje od drugih električnih uređaja (npr., TV, radio, računalo)

#### **NEMOJTE jedinicu instalirati na sljedećim lokacijama:**

- U blizini izvora topline, pare ili zapaljivog plina
- U blizini zapaljivih stvari kao što su zavjese ili odjeća
- U blizini prepreka koje mogu blokirati cirkulaciju zraka
- U blizini vrata
- Na lokaciju pod direktnoj sunčevoj svjetlosti

#### ● **NAPOMENA: Za instalaciju proizvoda**

Ako nema fiksnih cijevi rashladnog sredstva:

Prilikom odabira lokacije imajte na umu kako biste trebali ostaviti dovoljno prostora za rupu u zidu (pogledajte korak bušenja rupe u zidu za spajanje cijevi) za signalni kabel i cijevi rashladnog sredstva, koji povezuju unutarnju i vanjsku jedinicu. Zadani položaj za sve cijevi je desna strana unutarnje jedinice (kada ste okrenuti prema jedinici). Međutim, jedinica može primiti cijevi i lijevo i desno

## 2 Bušenje rupe u zidu za spojne cijevi

### Određivanje lokacije rupe u zidu

#### ● **NAPOMENA: VELIČINA RUPE U ZIDU**

Veličina rupe u zidu određena je spojnim cijevima. Kada je veličina spojne cijevi sa strane plina  $\varnothing 16$  mm (5/8") ili više, rupa u zidu treba biti 90 mm (3-9/16"). Ako je veličina spojne cijevi manja od  $\varnothing 16$  mm (5/8"), rupa u zidu treba biti 65 mm (2-1/2").

#### Korak 1:

Uklonite vijak koji pričvršćuje montažnu ploču na stražnju stranu unutarnje jedinice.

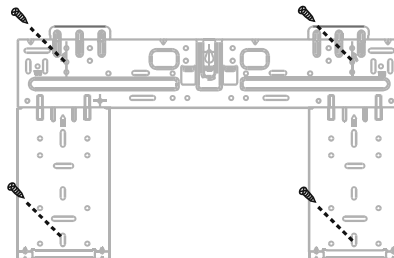
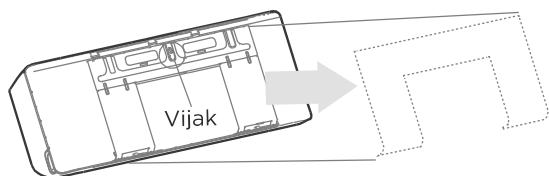

#### Korak 2:

Različiti modeli imaju različite montažne ploče. Za različite zahtjeve prilagodbe, oblik montažne ploče može biti malo drugačiji. Ali ugradbene dimenzije su iste za istu veličinu unutarnje jedinice. Za primjer, pogledajte tip A i tip B

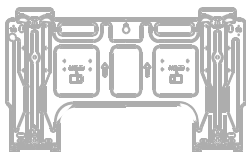

Tip A

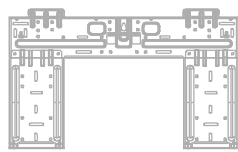

Tip B

#### Korak 3:

Pričvrstite montažnu ploču na zid isporučenim vijcima. Uvjerite se da je montažna ploča ravna uza zid.

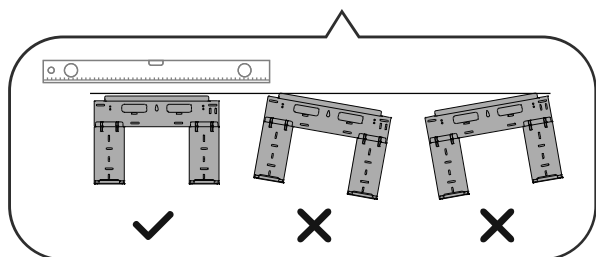

Pravilna orijentacija montažne ploče

#### **NAPOMENA: ZA BETONSKE I ZIDOVE OD CIGLE**

Ako je zid napravljen od cigle, betona ili sličnog materijala, izbušite rupe promjera 5 mm (0,2 inča) u zidu i umetnite priložene klinove. Zatim pričvrstite montažnu ploču na zid pritezanjem vijaka direktno u stezne tiple.

#### Korak 4:

Provjerite montažnu ploču koju imate. Odredite mjesto rupe u zidu na temelju položaja montažne ploče. Iscrtkani pravokutni okvir iznad pokazuje veličinu vašeg proizvoda

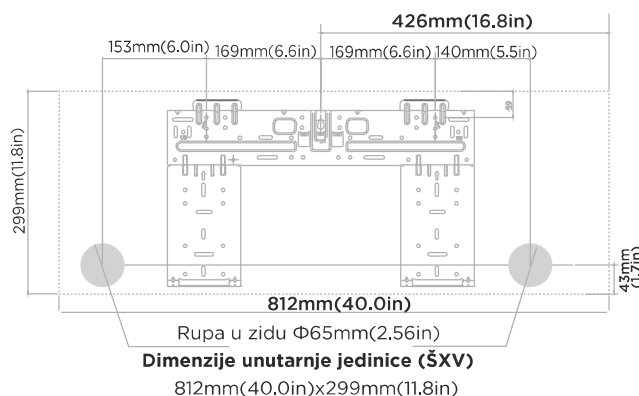

## **⚠ OPREZ**

Prilikom bušenja rupe u zidu, pazite da izbjegnute žice, cijevi i druge osjetljive komponente.

### **Bušenje rupe u zidu**

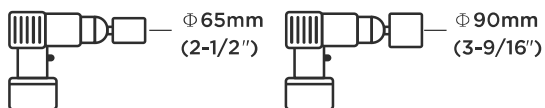

Koristeći 65mm (2-1/2") ili 90mm(3-9/16")  
Krunsko svrdlo (ovisno o modelu)

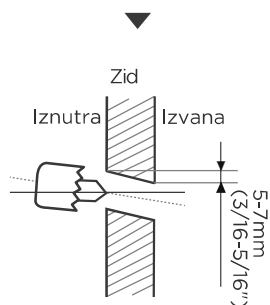

Probušite rupu u zidu

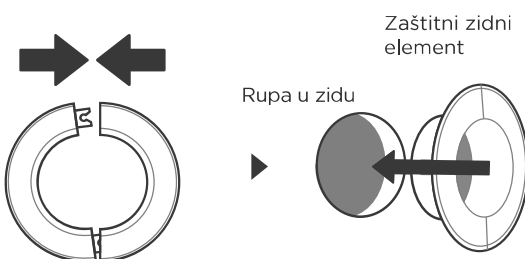

U rupu postavite zaštitni element

#### **Korak 1:**

Koristeći krunsko svrdlo od 65 mm (2,5") ili 90 mm (3,54") (ovisno o modelima), izbušite rupu u zidu. Uvjerite se da je rupa izbušena pod blagim kutom prema dolje, tako da vanjski kraj rupe bude niži od unutarnjeg za oko 5 mm do 7 mm (3/16-5/16"). To će osigurati pravilnu drenažu vode.

#### **Korak 2:**

U rupu postavite zaštitni element. To štiti rubove rupe i pomoći će da se zabrtvi kada završite s postupkom instalacije.

**NAPOMENA**

Cijevi rashladnog sredstva nalaze se unutar izolacijske uvodnice pričvršćene na stražnju stranu jedinice. Morate pripremiti cijev prije nego što je provučete kroz rupu u zidu.

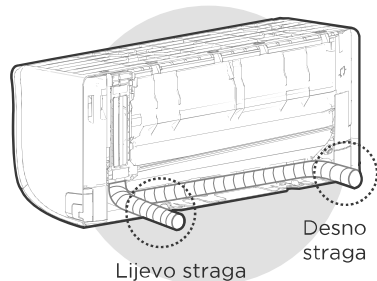
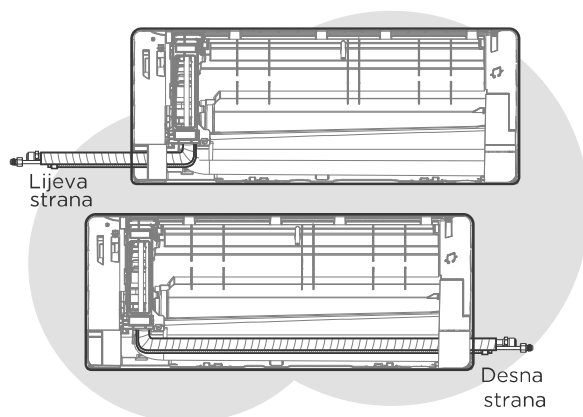
**Priprema cijevi rashladnog sredstva**

Četiri mogućnosti za izlaz cijevi

**Korak 1:**

Na temelju položaja rupe u zidu u odnosu na montažnu ploču, odaberite stranu s koje će cijev izlaziti iz jedinice. Imate četiri mogućnosti za smjer izlaza cijevi. Pogledajte ispod za detalje o kutu cijevi.

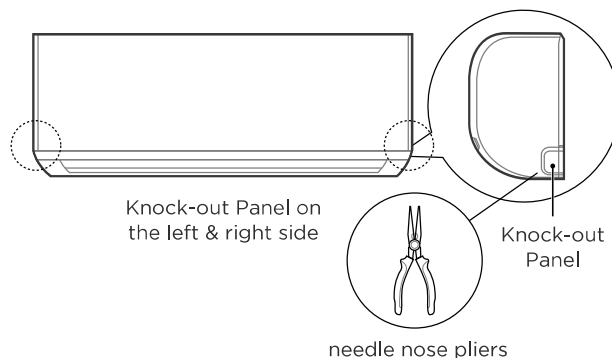
**Korak 2:**

Ako je rupa u zidu iza jedinice, držite perforirajuću ploču na mjestu. Ako je rupa u zidu sa strane unutarnje jedinice, uklonite plastičnu perforirajuću ploču s te strane jedinice. Koristite kliješta s tankim vrhom ako je plastičnu ploču previše teško ukloniti rukom.

**Napomena:** U perforiranoj ploči napravljen je utor kako bi se lakše rezala. Veličina utora određena je promjerom cjevovoda.

**Korak 3:**

Spojite cijevi rashladnog sredstva unutarnje jedinice na spojne cijevi koje će spajati unutarnju i vanjsku jedinicu. Za detaljne upute pogledajte odlomak **Spajanje cijevi rashladnog sredstva** u ovom priručniku.

**NAPOMENA:** Ako su postojeće spojne cijevi već ugrađene u zid, prijedite direktno na korak **spajanja drenažnog crijeva**.

**OPREZ**

Budite izuzetno oprezni da ne udubite ili oštetite cijevi dok ih savijate dalje od jedinice. Sva udubljenja u cijevima utjecat će na performanse jedinice.

## Spajanje drenažnog crijeva

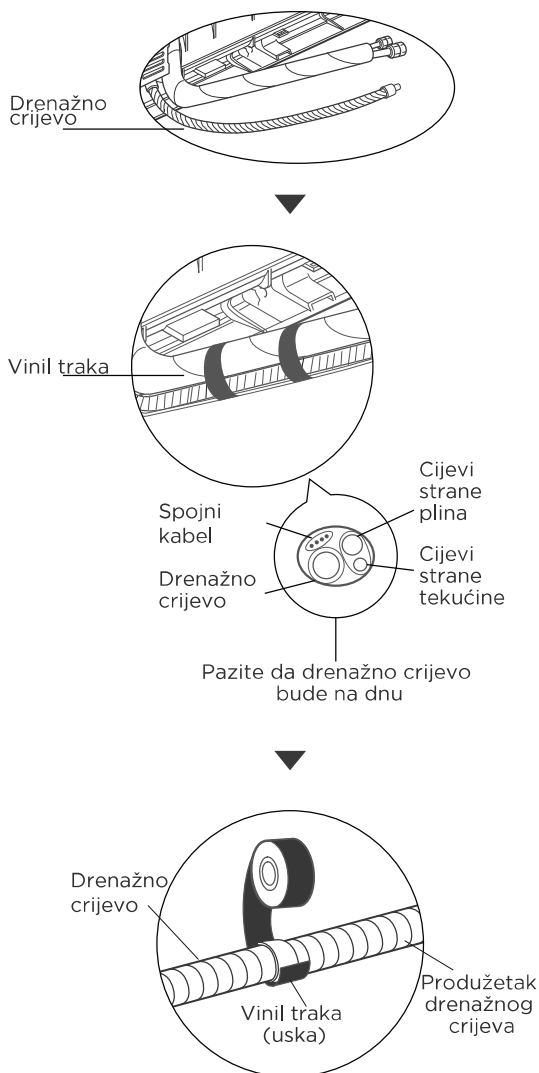

### ⚠ NAPOMENA O POSTAVLJANJU DRENAŽNOG CRIJEVA

Obavezno postavite drenažno crijevo prema sljedećim slikama.

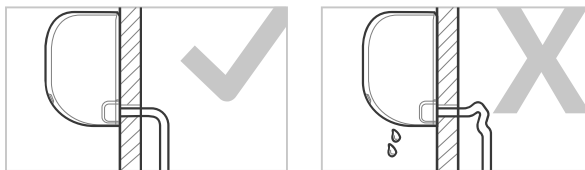

#### PRAVILNO

Osigurajte da nema udubina ili pregiba kako bi se osigurala pravilna drenaža

#### POGREŠNO

Pregibi u drenažnom crijevu će kreirati blokade vode

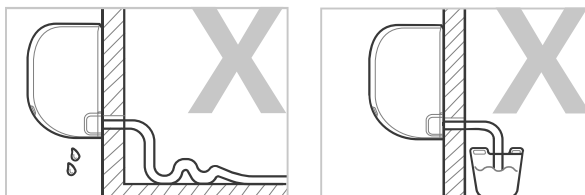

#### POGREŠNO

Pregibi u drenažnom crijevu će kreirati blokade vode.

#### HPOGREŠNO

Nemojte stavljati završetak drenažnog crijeva u vodu ili spremnike za skupljanje vode. To će spriječiti pravilnu drenažu

#### Korak 1:

Drenažno crijevo može se pričvrstiti na lijevu ili desnu stranu. Kako biste osigurali pravilnu drenažu, pričvrstite drenažno crijevo na istu stranu kao i cijevi rashladnog sredstva. Pričvrstite nastavak drenažnog crijeva (kupuje se odvojeno) na kraj drenažnog crijeva.

- Čvrsto omotajte spojnu točku teflonskom trakom kako biste osigurali dobro brtvljenje i spriječili curenje.
- Za dio drenažnog crijeva koji će ostati u zatvorenom prostoru, omotajte ga pjenastom izolacijom cijevi kako biste spriječili kondenzaciju.
- Uklonite filter za zrak i ulijte malu količinu vode u drenažnu posudu kako biste bili sigurni da voda neometano teče iz jedinice

### ⚠ OPREZ

#### ZAČEPITE NEKORIŠTENI DRENAŽNI OTVOR

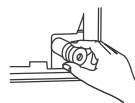

Kako biste spriječili neželjeno curenje, morate začepiti neiskorišteni drenažni otvor isporučeni gumenim čepom.

**⚠ UPOZORENJE**

- Prije izvođenja bilo kakvih električnih radova, pročitajte ove upute.
- Prije izvođenja bilo kakvih radova na elektrici ili ožičenju, isključite glavno na pajanje sustava.

1. Sve ožičenje mora biti u skladu s lokalnim i nacionalnim električnim propisima i zakonima, te ih mora instalirati ovlaštenu električar.
2. Svi električni priključci moraju biti izvedeni prema dijagramu električnog spajanja koji se nalazi na pločama unutarnje i vanjske jedinice.
3. Ako postoji ozbiljan sigurnosni problem s napajanjem, odmah prekinite rad. Objasnite situaciju klijentu i prekinite instalaciju dok se sigurnosni problem pravilno ne riješi.
4. Ako spajate napajanje na fiksno ožičenje, prekidač ili preklopnik kruga koji isključuje sve polove i ima razmak između kontakata od najmanje 3 mm mora biti ugrađen u fiksno ožičenje. Kvalificirani tehničar mora koristiti odobreni prekidač ili sklopku.
5. Samo jedinica i nijedan drugi uređaj ili utičnica ne smiju biti spojeni na pojedinačnu utičnicu strujnog kruga.
6. Provjerite jeste li pravilno uzemlili klima uređaj.
7. Svaka žica mora biti čvrsto spojena. Labavo ožičenje može uzrokovati pregrijavanje priključaka, što može dovesti do kvara proizvoda i mogućeg požara.
8. Ne dopustite da se žice dodiruju ili naslanjaju na cijevi rashladnog sredstva, kompresor ili bilo koje pokretne dijelove unutar jedinice.
9. Kako biste izbjegli strujni udar, nikada ne dirajte električne komponente ubrzo nakon što je napajanje isključeno. Nakon isključivanja napajanja, uvijek pričekajte 10 minuta ili više prije nego što dodirnete električne komponente.
10. Napon napajanja treba biti unutar 90-110% nazivnog napona. Nedovoljno napajanje može uzrokovati kvar, strujni udar ili požar.

**⚠ UPOZORENJE**

Sve ožičenje mora biti izvedeno strogo u skladu sa dijagramom ožičenja koji se nalazi na stražnjoj strani prednje ploče unutarnje jedinice.

**Spajanje signalnog i kabela napajanja**

Signalni kabel omogućuje komunikaciju između unutarnje i vanjske jedinice. Prvo morate odabrati odgovarajuću veličinu kabela prije nego što ga pripremite za spajanje.

**Vrste kabela (nije primjenjivo za Sjevernu Ameriku)**

- Unutarnji kabel za napajanje (ako je primjenjivo): H05VV-F ili H05V2V2-F
- Kabel za vanjsko napajanje: H07RN-F ili H05RN-F
- Signalni kabel: H07RN-F

**Minimalni poprečni presjeci kabela napajanja i signalnog kabela (za referencu)**

Nazivna struja uređaja (A)	Nazivni poprečni presjek (mm <sup>2</sup> )
> 3i ≤ 6	0.75
> 6i ≤ 10	1
> 10i ≤ 16	1.5
> 16i ≤ 25	2.5
> 25i ≤ 32	4
> 32i ≤ 40	6

**ODABIR PRAVILNE VELIČINE KABELA**

Veličina kabela za napajanje, signalnog kabela, osigurača i potrebne sklopke određena je maksimalnom strujom jedinice. Maksimalna struja navedena je na natpisnoj pločici koja se nalazi na bočnoj ploči jedinice. Za odabir pravog kabela, osigurača ili sklopke pogledajte ovu natpisnu pločicu.

1. Otvorite prednju ploču unutarnje jedinice.
2. Pomoću odvijača otvorite poklopac kutije ožičenja na desnoj strani jedinice. Ovo će otkriti priključni blok.
3. Odvijte stezaljku kabela ispod priključnog bloka i postavite je sa strane.
4. Uklonite plastičnu ploču s donje lijeve strane (okrenutu prema stražnjoj strani jedinice).
5. Provucite signalnu žicu kroz ovaj otvor, od stražnjeg prema prednjem dijelu jedinice.
6. Okrenuti prema prednjoj strani jedinice, spojite žicu prema dijagramu ožičenja unutarnje jedinice, spojite u-spojnicu i čvrsto zavrnite svaku žicu na odgovarajući priključak.
7. Nakon provjere je li svaka veza čvrsta, koristite kabelsku stezaljku za pričvršćivanje signalnog kabela na jedinicu. Čvrsto zavrnite stezaljku kabela.
8. Vratite poklopac ožičenja na prednju stranu jedinice i plastičnu ploču na stražnjoj strani

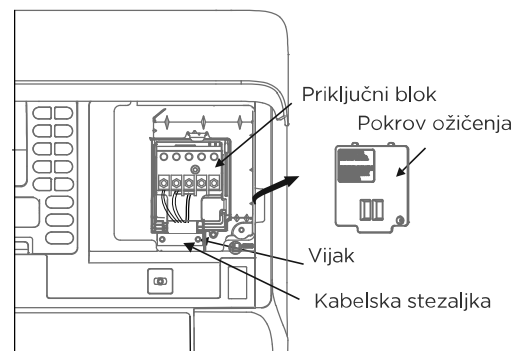



## U Sjevernoj Americi

**NAPOMENA:** Odaberite vrstu kabela u skladu s lokalnim električnim kodovima i propisima. Odaberite pravu veličinu kabela u skladu s minimalnom strujom navedenoj na natpisnoj pločici jedinice.

1. Okrenuti prema stražnjoj strani jedinice, uklonite plastičnu ploču na donjoj lijevoj strani.
2. Kao što je prikazano na slici, umetnite žice uključujući žicu za uzemljenje u cijev i pričvrstite ih sigurnosnom maticom na montažnu ploču vodiča.
3. Uskladite boje žica s brojevima priključaka na priključnim blokovima unutarne i vanjske jedinice i čvrsto pričvrstite žice na odgovarajuće priključke.
4. Spojite žice za uzemljenje na odgovarajuće priključke.
5. Povucite žice i provjerite jesu li žice sigurno pričvršćene za priključni blok

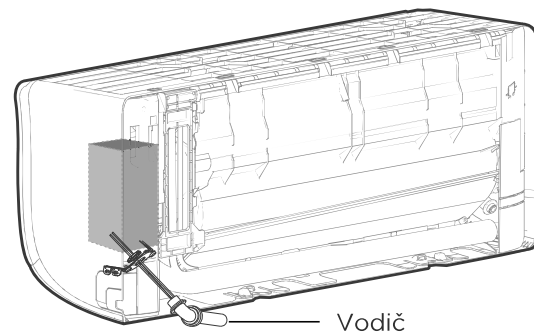

### **⚠ NE MIJEŠAJTE VODIČE POD NAPONOM I VODIČE NULE**

To je opasno i može uzrokovati kvar klima uređaja

### ● NAPOMENA

Prije provlačenja cijevi, drenažnog crijeva i signalnog kabela kroz rupu u zidu, morate ih skupiti u snop kako biste uštedjeli prostor, zaštitili ih i izolirali.

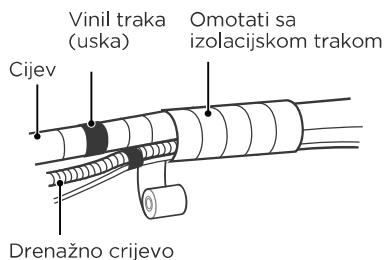
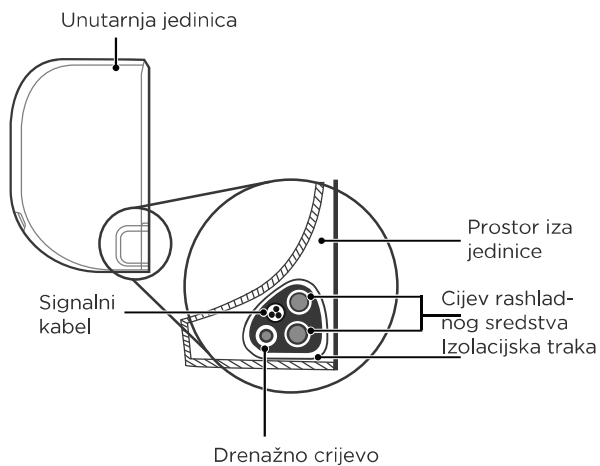

#### Korak 1:

Skupite drenažno crijevo, cijevi za rashladno sredstvo i signalni kabel kao što je prikazano na slici (Nije primjenjivo za neke lokacije u Sjevernoj Americi).

#### Korak 2:

Pomoću ljepljive vinil trake pričvrstite drenažno crijevo na donju stranu cijevi rashladnog sredstva

#### Korak 3:

Pomoću izolacijske trake čvrsto omotajte cijevi rashladnog sredstva, signalnu žicu i drenažno crijevo. Još jednom provjerite jesu li sve stavke omotane.

#### Nemojte omatati signalni kabel s drugim žicama

Dok skupljate ove stavke zajedno, nemojte ispreplitati niti križati signalni kabel s bilo kojim drugim ožičenjem.

### DRENAŽNO CRIJEVO NE SMIJE BITI NA DNU

Provjerite je li drenažno crijevo na dnu snopa. Stavljanje drenažnog crijeva na vrh snopa može uzrokovati prelijevanje drenažne posude, što može dovesti do požara ili oštećenja vodom.

### NEMOJTE OMATATI KRAJEVE CIJEVI

Prilikom omatanja snopa, krajevi cijevi neka budu nezamotani. Morate im pristupiti kako biste ispitali curenje na kraju procesa instalacije (pogledajte odlomak Provjera elektrike i Provjere curenja u ovom priručniku)

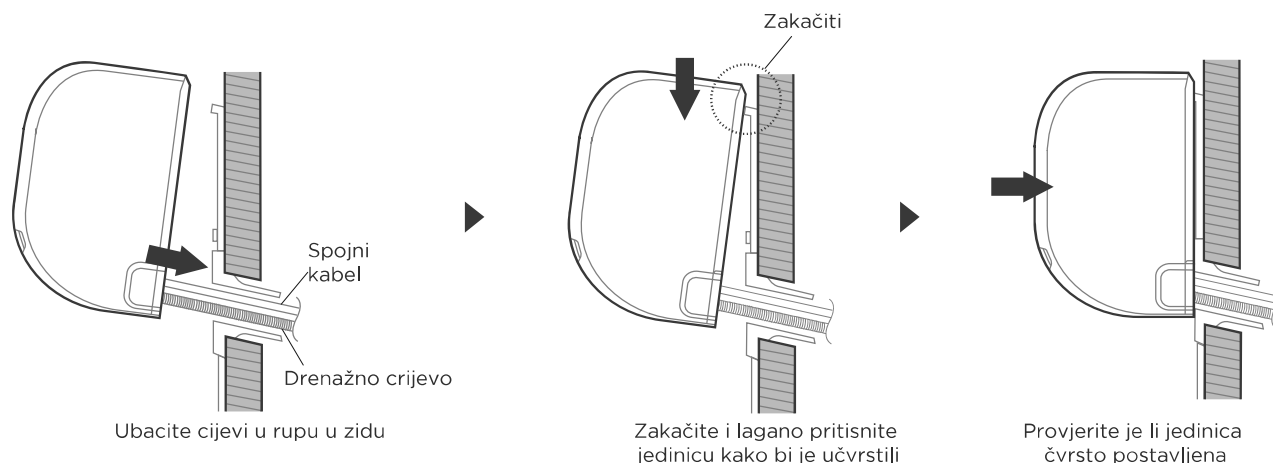

### Ako ste instalirali nove spojne cijevi na vanjsku jedinicu, učinite sljedeće:

- Ako ste već provukli cijevi rashladnog sredstva kroz rupu u zidu, prijedite na korak 4. U suprotnom, još jednom provjerite jesu li krajevi cijevi rashladnog sredstva zabrtvljeni kako biste spriječili ulazak prljavštine ili stranih materijala u cijevi.
- Polako provucite omotani snop cijevi za rashladno sredstvo, drenažnog crijeva i signalne žice kroz rupu u zidu.
- Zakačite gornji dio unutarnje jedinice na gornju kuku montažne ploče.
- Provjerite je li jedinica čvrsto pričvršćena na montažnu ploču laganim pritiskom na lijevu i desnu stranu jedinice. Jedinica se ne smije tresti ili pomicati.
- Ravnomjernim pritiskom pritisnite donju polovicu jedinice. Nastavite gurati prema dolje dok jedinica ne škljocne na kukice duž dna montažne ploče.
- Ponovo provjerite je li jedinica čvrsto postavljena laganim pritiskom na lijevu i desnu stranu jedinice

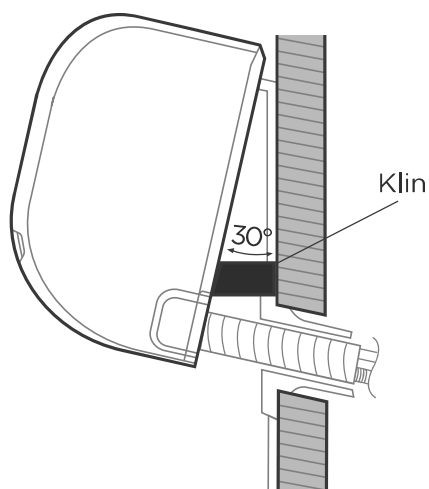

### Ako su cijevi rashladnog sredstva već ugrađene u zid, učinite sljedeće:

- Zakačite gornji dio unutarnje jedinice na gornju kuku montažne ploče.
- Koristite držač ili klin da poduprete jedinicu, što vam pruža dovoljno prostora za spajanje cijevi rashladnog sredstva, signalnog kabela i drenažnog crijeva.
- Spojite drenažno crijevo i cijevi rashladnog sredstva (upute potražite u odlomku Spajanje cijevi rashladnog sredstva u ovom priručniku).
- Držite spojnu točku cijevi izloženom kako biste izvršili test curenja (pogledajte odlomak Provjere elektrike i Provjere curenja u ovom priručniku).
- Nakon ispitivanja nepropusnosti, omotajte mjesto spajanja izolacijskom trakom.
- Uklonite nosač ili klin koji podupire jedinicu. Ravnomjernim pritiskom pritisnite donju polovicu jedinice. Nastavite pritiskati prema dolje dok jedinica ne škljocne na kukice duž dna montažne ploče

## ● NAPOMENA: JEDINICA JE PODESIVA

Imajte na umu da su kuke na montažnoj ploči manje od rupa na stražnjoj strani jedinice. Ako ustanovite da nemate dovoljno prostora za spajanje ugrađenih cijevi na unutarnju jedinicu, jedinicu možete podesiti lijevo ili desno za oko 30-50 mm (1,18-1,96 in), ovisno o modelu.



## ⚠ OPREZ

Kako bi jedinice prihvatile sljedeće priključke cijevi, striktno izvodite radove na cjevovodu u skladu sa sljedećim uputama.

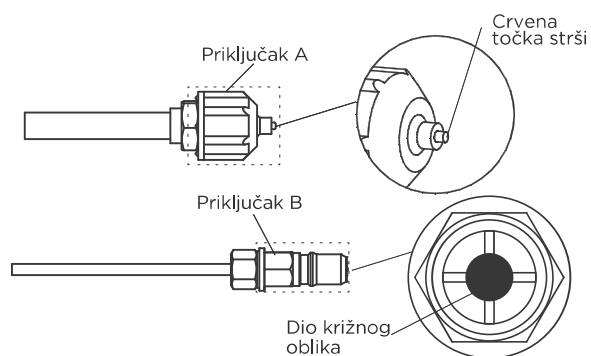

- Prije spajanja cijevi rashladnog sredstva uvijek nosite radne rukavice i naočale i imajte na umu da priključci A i B ne smiju biti direktno okrenuti prema ljudima.
- Nastavite pritiskati križni dio priključka B alatom oko 5-10 sekundi dok se crvena izbočena točka priključka A potpuno ne uvuče.
- Uklonite priključke A i B, zatim spojite cijevi rashladnog sredstva između unutarne i vanjske jedinice.

## Instalacija vanjske jedinice

### 1 Odabir lokacije instalacije

#### ● **NAPOMENA: PRIJE INSTALACIJE**

Prije instalacije vanjske jedinice morate odabrati odgovarajuću lokaciju. Slijede standardi koji će vam pomoći da odaberete odgovarajuću lokaciju za jedinicu.

#### Pravilna lokacija za instalaciju zadovoljava sljedeće standarde:

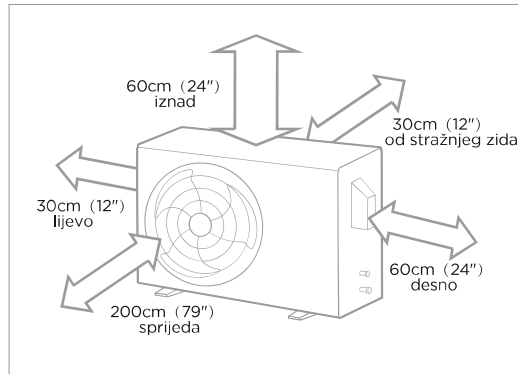

✓ Dobro kruženje zraka i ventilacija



✓ Čvrsta i kruta—lokacija može izdržati jedinicu i neće vibrirati.



✓ Buka jedinice neće ometati druge osobe



✓ Zaštićena od dužih razdoblja direktne sunčeve svjetlosti ili kiše

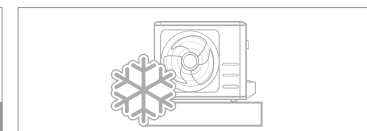

✓ Ako se očekuje snijeg, poduzmite mjere za sprečavanje nakupljanja leda i oštećenja namota

✓ Zadovoljava sve prostorne zahtjeve prikazane u gornjem dijagramu prostora instalacije

#### ● **NAPOMENA:**

Instalirajte jedinicu slijedeći lokalne zakone i propise, može doći do male razlike između različitih regija

#### ⚠ **ВНИМАНИЕ:**

##### POSEBNA RAZMATRANJA ZA EKSTREMNE VREMENSKE UVJETE

###### Ako je jedinica izložena jakom vjetru:

Instalirajte jedinicu tako da ventilator za izlaz zraka bude pod kutom od 90° u odnosu na smjer vjetra. Ako je potrebno, izgradite barijeru ispred jedinice kako biste je zaštitili od iznimno jakih vjetrova. Pogledajte slike ispod.

###### Ako je jedinica često izložena jakoj kiši ili snijegu:

Izgradite sklonište iznad jedinice kako biste je zaštitili od kiše ili snijega. Pazite da ne ometate protok zraka oko jedinice

###### Ako je jedinica često izložena slanom zraku (morska obala):

Koristite vanjsku jedinicu koja je posebno dizajnirana za otpornost na koroziju.

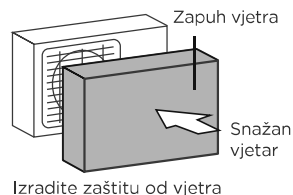
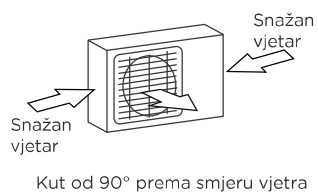

#### **NEMOJTE instalirati jedinicu na sljedeće lokacije:**

- ✗ U blizini prepreke koja će blokirati ulaze i izlaze zraka.
- ✗ U blizini javne ulice, u napućenim područjima ili gdje će buka iz jedinice smetati drugima.

- ✗ U blizini životinja ili biljaka koje će ometati ispuštanju vrućeg zraka
- ✗ U blizini bilo kojeg izvora zapaljivog plina

- ✗ Na mjestu koje je izloženo velikim količinama prašine
- ✗ Na mjestu izloženom prekomjernoj količini slanog zraka

### ● NAPOMENA: PRIJE INSTALACIJE

Prije pričvršćivanja vanjske jedinice vijcima morate ugraditi drenažni spoj na dnu jedinice. Za jedinice s ugrađenom baznom posudom s višestrukim rupama za drenažu, drenažni spoj nije potrebno ugraditi.

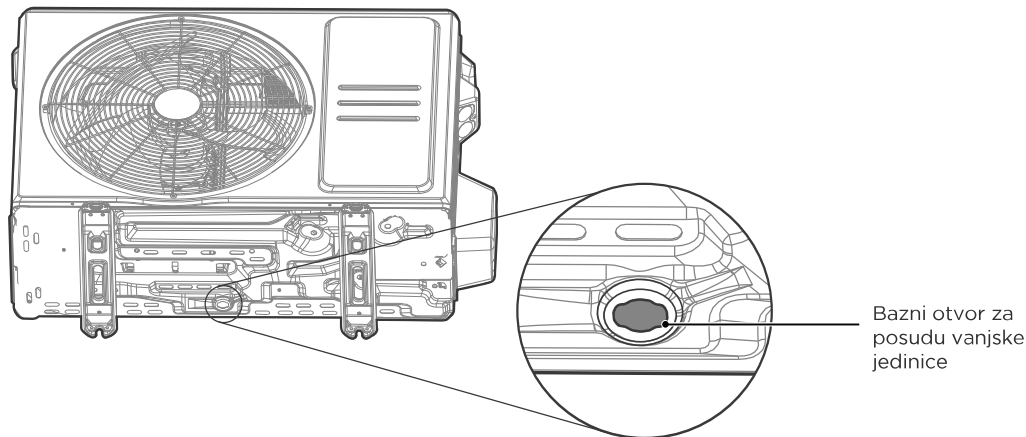

### Korak 1:

Locirajte bazni otvor vanjske jedinice.

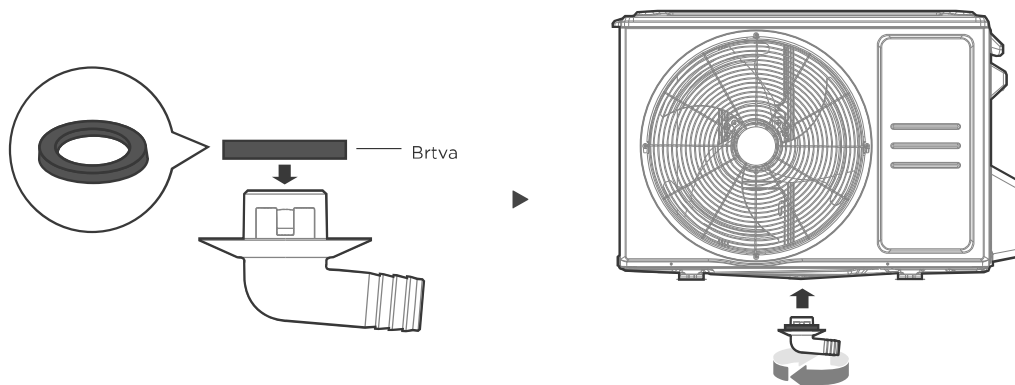

### Korak 2:

- Postavite gumenu brtvu na kraj drenažnog spoja koji će se spojiti na vanjsku jedinicu.
- Umetnite drenažni spoj u rupu u baznoj posudi jedinice. Drenažni spoj će kliknuti na mjesto.
- Spojite nastavak drenažnog crijeva (nije uključeno) na drenažni spoj za preusmjerenje vode iz jedinice tijekom režima grijanja

### ● NAPOMENA: U HLADNIM KLIMAMA

U hladnim klimatskim uvjetima, provjerite je li drenažno crijevo što je moguće okomitije kako biste osigurali brzu drenažu vode. Ako voda istječe presporo, može se smrznuti u crijevu i poplaviti jedinicu

### 3 Sidrenje vanjske jedinice

#### ▲ UPOZORENJE

TIJEKOM BUŠENJA BETONA, U SVAKOM TRENUTKU KORISTITE ZAŠTITU ZA OČI.

- Vanjska jedinica može se pričvrstiti za tlo ili za zidni nosač pomoću vijka (M10). Pripremite bazu za ugradnju jedinice prema dolje navedenim dimenzijama.
- Slijedi popis različitih veličina vanjskih jedinica i razmak između njihovih nožica za ugradnju.

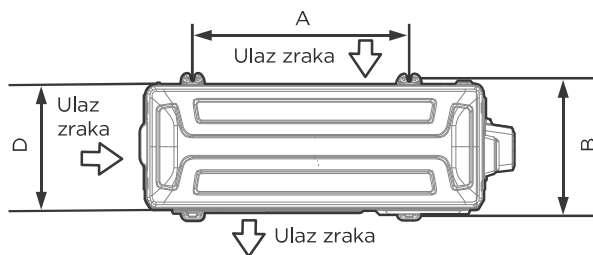

Pogled odozgora

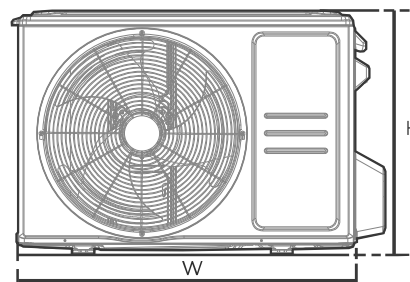

Pogled sprijeda

Dimenzije vanjske jedinice (mm) ŠxVxD	Dimenzije ugradnje	
	Udaljenost A (mm)	Udaljenost A (mm)
680x542x248 (26.8"x 21.3"x 9.8")	452 (17.8")	230 (9.1")
720x495x270 (28.3"x 19.5"x 10.6")	452 (17.8")	255 (10.0")
765x555x303 (30.1"x 21.8"x 11.9")	452 (17.8")	286(11.3")
805x554x330 (31.7"x 21.8"x 12.9")	511 (20.1")	317 (12.5")
890x673x342 (35.0"x 26.5"x 13.5")	663 (26.1")	354 (13.9")
946x810x420 (37.2"x 31.9"x 16.5")	673 (26.5")	403 (15.9")
946x810x410 (37.2"x 31.9"x 16.1")	673 (26.5")	403 (15.9")

#### Ako jedinicu ugradite na tlo ili na betonsku platformu za ugradnju, učinite sljedeće:

- Označite položaje za četiri ekspanzijska vijka na temelju tablice dimenzija.
- Prethodno izbušite rupe za ekspanzijske vijke.
- Postavite maticu na kraj svakog ekspanzijskog vijka. Zabijte ekspanzijske vijke u prethodno izbušene rupe.
- Uklonite matice s ekspanzijskih vijaka i postavite vanjsku jedinicu na vijke.
- Stavite podlošku na svaki ekspanzijski vijak i zamijenite matice.
- Pomoću ključa pritegnite svaku maticu dok se ne učvrst

#### Ako jedinicu ugradite na zidni nosač, učinite sljedeće:

- Označite položaj rupa za nosače na temelju tablice dimenzija.
- Prethodno izbušite rupe za ekspanzijske vijke.
- Stavite podlošku i maticu na kraj svakog ekspanzijskog vijka. Provucite ekspanzijske vijke kroz rupe u montažnim nosačima, postavite montažne nosače na mjesto i zabijte ekspanzijske vijke u zid.
- Provjerite jesu li montažni nosači ravni.
- Pažljivo podignite jedinicu i postavite njene noge za ugradnju na nosače. Čvrsto pričvrstite jedinicu za nosače.
- Ako je dopušteno, ugradite jedinicu s gumenim brtvama kako biste smanjili vibracije i buku

#### ▲ OPREZ

Provjerite je li zid napravljen od pune cigle, betona ili sličnog čvrstog materijala. Zid mora moći izdržati najmanje četiri puta veću težinu jedinice.

### ⚠ UPOZORENJE-Prije operacije

- Svi radovi na ožičenju moraju se izvoditi strogo u skladu s dijagramom ožičenja koji se nalazi unutar poklopca ožičenja vanjske jedinice.
- Prije izvođenja bilo kakvih radova na elektrici ili ožičenju, isključite glavno napajanje sustava.

#### Priprema kabela za spajanje

Odaberite odgovarajući kabel prema "Vrste kabela" na stranici 24.

- Pomoću alata za skidanje izolacije skinite gumeni omotač s oba kraja kabela kako biste otkrili oko 40 mm (1,57 inča) žice.
- Skinite nekoliko milimetara izolacije s krajeva žica.
- Koristeći alat a krimpiranje, stegnite u-elemente na krajevima žica

#### Pazite na žicu pod naponom

Prilikom krimpiranja žica, osigurajte da se žica pod naponom ("L") jasno razlikuje od ostalih žica. Priključni blok vanjske jedinice zaštićen je poklopcem električnog ožičenja na bočnoj strani jedinice. Sveobuhvatan dijagram ožičenja otisnut je na unutarnjoj strani poklopca ožičenja.

- Odvijte poklopac električnog ožičenja i uklonite ga.
- Odvijte stezaljku kabela ispod priključnog bloka i postavite je sa strane.
- Spojite žicu prema dijagramu ožičenja i čvrsto pričvrstite U-elemente svake žice na odgovarajuću stezaljku.
- Nakon što provjerite je li svaki spoj čvrst, omotajte žice okolo kako biste spriječili da kišnica teče u priključak.
- Pomoću kableske stezaljke pričvrstite kabel za jedinicu. Čvrsto zavrnite stezaljku kabela.
- Izolirajte neiskorištene žice PVC električnom trakom. Postavite ih tako da ne dodiruju električne ili metalne dijelove.
- Vratite poklopac žice na bočnu stranu jedinice i pričvrstite ga vijcima

**NAPOMENA:** Ako stezaljka kabela izgleda kao na slici s desne strane, odaberite odgovarajući otvor prema promjeru žice.

#### Odabir prave veličine kabela

Veličina potrebnog kabela za napajanje, signalnog kabela, osigurača i prekidača određena je maksimalnom strujom jedinice. Maksimalna struja navedena je na natpisnoj pločici koja se nalazi na bočnoj ploči jedinice.

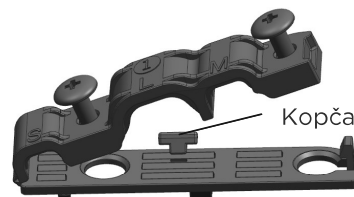
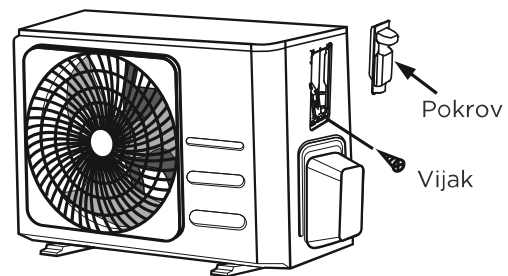

Tri veličine rupa: mala, velika, srednja

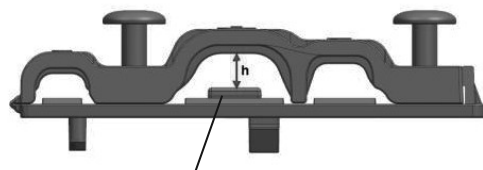

Ako kabel nije dobro učvršćen, koristite kopču kako bi ga izvukli, tako da se može čvrsto stegnuti.



## U Sjevernoj Americi

Priključni blok vanjske jedinice zaštićen je poklopcem električnog ožičenja na bočnoj strani jedinice. Detaljan dijagram ožičenja zalijepljen je s unutarnje strane poklopca ožičenja.

- Uklonite poklopac ožičenja s jedinice otpuštanjem 3 vijka.
- Skinite kapice s ploče vodiča.
- Privremeno montirajte cijevi vodiča (nisu u paketu) na ploču vodiča.
- Pravilno spojite vodiče napajanja i niskonaponske vodiče na odgovarajuće priključke na priključnom bloku.
- Uzemljite jedinicu u skladu s lokalnim propisima.
- Pazite da svaku žicu dimenzionirate tako da bude nekoliko inča duža od potrebne duljine za ožičenje.
- Upotrijebite blokirajuće matice za pričvršćivanje cijevi vodiča

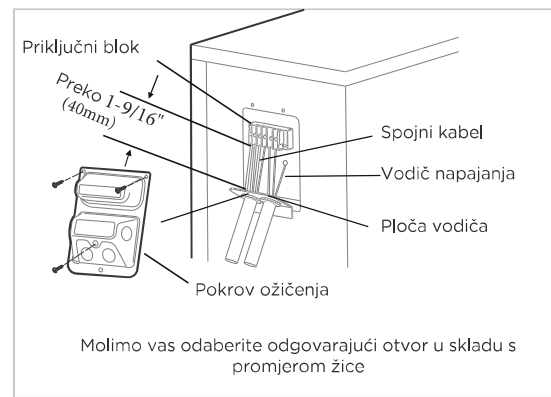

**NAPOMENA:** Odaberite odgovarajuću veličinu vodiča u skladu s minimalnom strujom navedenom na natpisnoj pločici jedinice.

## Kako pravilno spojiti vodiče

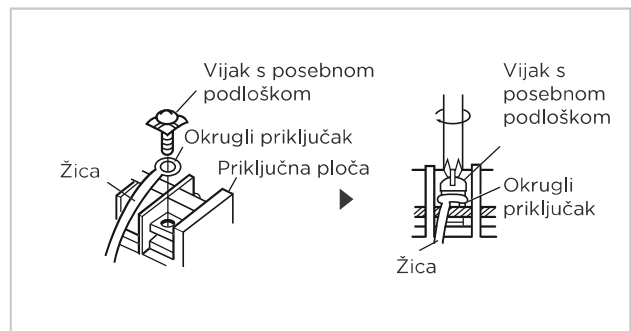
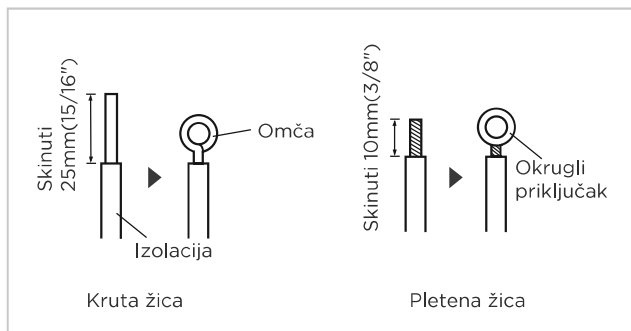

### Korak 1:

Završetak žice.

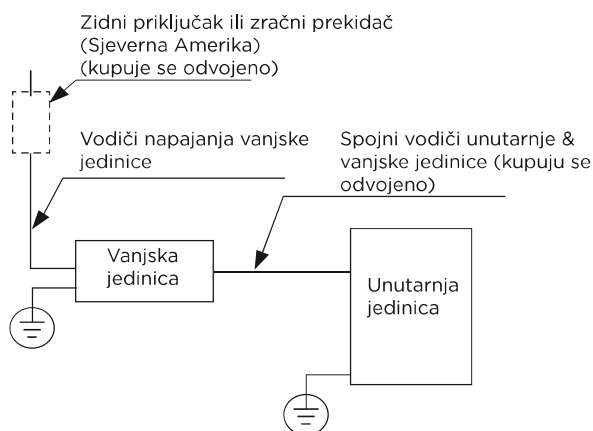

(A)

### Korak 2:

Spajanje linije na odgovarajuće priključke na priključnom bloku.

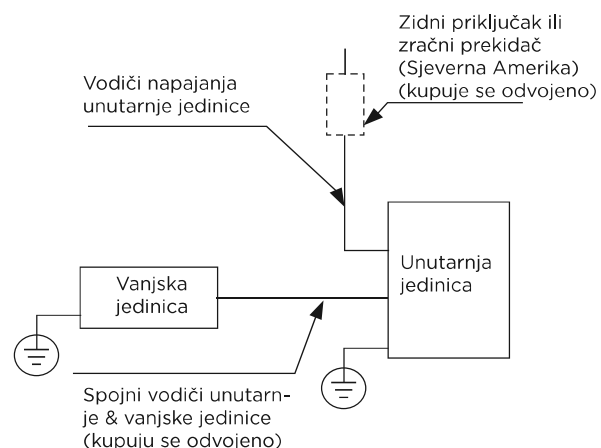

(B)

## Priključak cijevi rashladnog sredstva

### 1 Mjere opreza kod spajanja cijevi

#### ⚠ UPOZORENJE

PRILIKOM SPAJANJA CIJEVI RASHLADNOG SREDSTVA, NE DOPUSTITE DA U JEDINICU UĐU TVARI ILI PLINOVI OSIM NAVEDENOG RASHLADNOG SREDSTVA. PRISUTNOST DRUGIH PLINOVA ILI TVARI SMANJIT ĆE KAPACITET JEDINICE I MOŽE UZROKOVATI NEUOBIČAJENO VISOK TLAK U KRUGU HLAĐENJA. TO MOŽE UZROKOVATI EKSPLOZIJU I OZLJEDE.

#### Napomene o dužini cijevi

Duljina cijevi rashladnog sredstva utjecat će na performanse i energetska učinkovitost jedinice. Nazivna učinkovitost testirana je na jedinicama s cijevima duljine 5 metara (16,5 stopa). Potrebna je minimalna duljina cijevi od 3 metra kako bi se smanjile vibracije i prekomjerna buka

#### Maksimalan dužina i visina pada cijevi rashladnog sredstva prema modelu

Model	Kapacitet (BTU/h)	Maks. dužina (m)	Maks. visina pada (m)
R410A,R32 Inverterski split klima uređaj	< 15,000	25 (82ft)	10 (33ft)
	≥ 15,000 и < 24,000	30 (98.5ft)	20 (66ft)
	≥ 24,000 и < 36,000	50 (164ft)	25 (82ft)
	≥ 36,000 и < 60,000	65 (213ft)	30 (98.5ft)
R22 Split klima uređaj fiksne brzine	< 18,000	10 (33ft)	5 (16ft)
	≥ 18,000 и < 21,000	15 (49ft)	8(26ft)
	≥ 21,000 и < 35,000	20 (66ft)	10(33ft)
	≥ 35,000 и < 41,000	25 (82ft)	10 (33ft)
R410A, R32 Split klima uređaj fiksne brzine	< 18,000	20 (66ft)	8(26ft)
	≥ 18,000 и < 36,000	25 (82ft)	10(33ft)
	≥ 36,000 и < 60,000	30 (98.5ft)	15 (49ft)

#### Upute za spajanje – cijevi rashladnog sredstva

##### Korak 1: Rezanje cijevi

Prilikom pripremanja cijevi za rashladno sredstvo, posebno pazite da ih pravilno izrežete i pertlate. To će osigurati učinkovit rad i smanjiti potrebu za budućim održavanjem.

- Izmjerite udaljenost između unutarnje i vanjske jedinice.
- Rezačem cijevi izrežite cijev nešto duže od izmjerene udaljenosti.
- Provjerite je li cijev odrezana pod savršenim kutom od 90°.

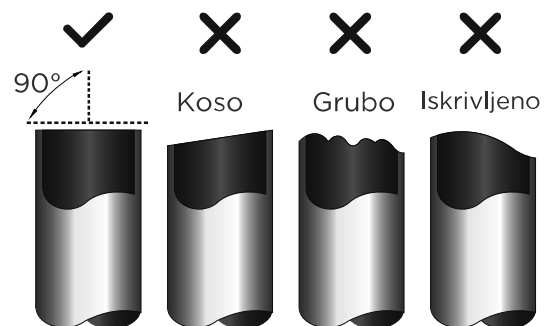

#### ⚠ NEMOJTE TIJEKOM REZANJA DEFORMIRATI CIJEV

Budite posebno oprezni da ne oštetite, udubite ili deformirate cijev tijekom rezanja. To će drastično smanjiti zagrijavanje.

## ⚠ OPREZ

PROVJERITE JE LI CIJEV JE RAVNOMJERNO PERTLANA I DA NEMA PUKOTINA.  
PROVJERITE JE LI JE CIJEV ZABRTVLJENA

### Korak 2: Uklanjanje strugotina

Strugotine mogu utjecati na hermetičko brtvljenje priključka cijevi rashladnog sredstva. Moraju se potpuno ukloniti.

- Držite cijev pod kutom prema dolje kako biste spriječili da strugotine upadnu u cijev.
- Pomoću razvrtača ili alata za skidanje ivica uklonite sve strugotine s odsječenog dijela cijevi.

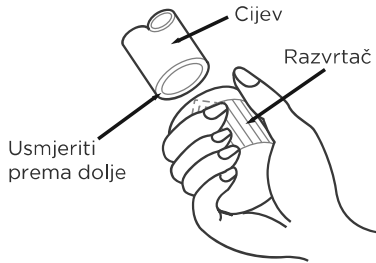

### Korak 3: Pertlanje krajeva cijevi

Pravilno pertlanje ključno je za postizanje hermetičkog brtvljenja.

- Nakon uklanjanja strugotina s odrezane cijevi, zalijepite krajeve PVC trakom kako biste spriječili ulazak stranih materijala u cijev.
- Obložite cijev izolacijskim materijalom.
- Postavite konusne matice na oba kraja cijevi. Provjerite jesu li okrenuti u pravom smjeru, jer ih ne možete staviti ili promijeniti njihov smjer nakon pertlanja

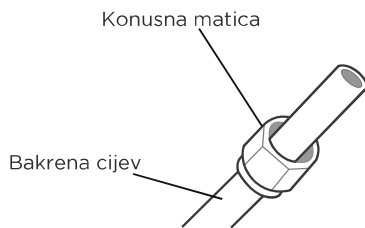

- Uklonite PVC cijev s oba kraja cijevi kada ste spremni provesti pertlanje.
- Stegnite kalup za pertlanje na kraj cijevi.
- Kraj cijevi mora izlaziti izvan ruba kalupa za pertlanje u skladu s dimenzijama prikazanim u

donjoj tablici

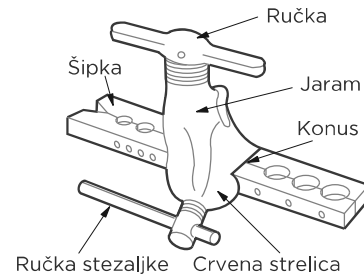

### PRODUŽETAK CIJEVI IZVAN KALUPA ZA PERTLANJE

Vanjski promjer cijevi (mm)	A (mm)	
	Min.	Maks.
Ø 6.35 (Ø 1/4")	0.7 (0.0275")	1.3 (0.05")
Ø 9.52 (Ø 3/8")	1.0 (0.04")	1.6 (0.063")
Ø 12.7 (Ø 1/2")	1.0 (0.04")	1.8 (0.07")
Ø 16 (Ø 5/8")	2.0 (0.078")	2.2 (0.086")
Ø 19 (Ø 3/4")	2.0 (0.078")	2.4 (0.094")

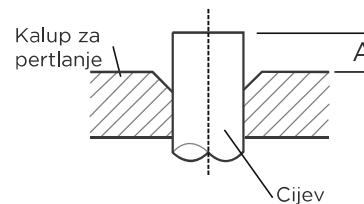

- Postavite alat za pertlanje na kalup.
- Okrenite ručicu alata za pertlanje u smjeru kazaljke na satu dok cijev ne bude u potpunosti pertlana.
- Uklonite alat za pertlanje i kalup za pertlanje, zatim pregledajte ima li na kraju cijevi pukotina ili čak pertlanja

## 2 Potreban moment kod spajanja cijevi

### ⚠ OPREZ

KOD SPAJANJA CIJEVI ZA RASHLADNO SREDSTVO, PAZITE DA NE KORISTITE PREVELIKI ZAKRETNI MOMENT ILI DA NA BILO KOJI NAČIN DEFORMIRATE CIJEV. PRVO TREBA SPOJITI NISKOTLAČNU CIJEV, PA VISOKOTLAČNU CIJEV.

#### MINIMALNI RADIJUS SAVIJANJA

Prilikom savijanja cijevi rashladnog sredstva, minimalni radiju savijanja je 10cm

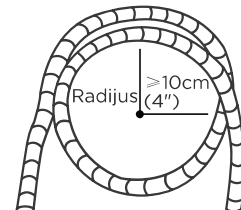

### Upute za spajanje cijevi unutarnje jedinice

#### Korak 1:

- Poravnajte osi cijevi koje ćete spojiti.

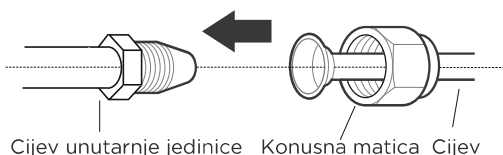

#### Korak 2:

- Rukom zategnite konusnu maticu što je čvršće moguće.
- Pomoću ključa uhvatite maticu na cijevi jedinice.
- Dok čvrsto držite maticu na cijevi jedinice, pomoću moment ključa zategnite konusnu maticu prema vrijednostima momenta u tablici sa zahtjevima momenta u nastavku. Lagano otpustite proširenu maticu, a zatim je ponovno zategnite

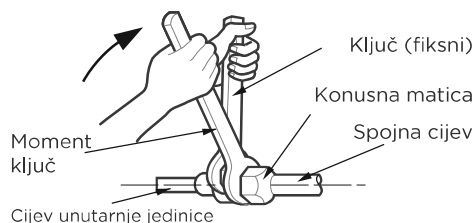

### ZAHTJEVI ZA MOMENT

Vanjski promjer cijevi(mm)	Moment pritezanja(N•m)	Dimenzije konusa(B)(mm)	Konus
Ø 6.35 (Ø 1/4")	18~20(180~200kgf.cm)	8.4~8.7 (0.33~0.34")	
Ø 9.52 (Ø 3/8")	32~39(320~390kgf.cm)	13.2~13.5 (0.52~0.53")	
Ø 12.7 (Ø 1/2")	49~59(490~590kgf.cm)	16.2~16.5 (0.64~0.65")	
Ø 16 (Ø 5/8")	57~71(570~710kgf.cm)	19.2~19.7 (0.76~0.78")	
Ø 19 (Ø 3/4")	67~101(670~1010kgf.cm)	23.2~23.7 (0.91~0.93")	

### ⊘ NEMOJTE KORISTITI PREVELIKI MOMENT

Pretjerana sila može slomiti maticu ili oštetiti cijevi rashladnog sredstva. Ne smijete prekoračiti specifikacije zakretnog momenta prikazane u gornjoj tablici.

### 3 Spajanje cijevi vanjske jedinice

#### **NAPOMENA**

U ovom odlomku još uvijek vrijede ZAHTEVI ZA MOMENT iz tablice koja je dana na prethodnoj stranici.

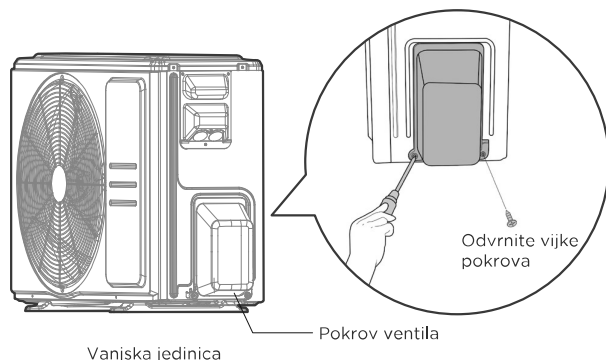

#### **Korak 1:**

- Odvrnite vijke s pokrova ventila sa strane vanjske jedinice.

#### **Korak 2:**

- Uklonite zaštitne kapice s krajeva ventila.
- Poravnajte pertlani kraj cijevi sa svakim ventilom i rukom zategnite maticu što je moguće čvršće.
- Pomoću ključa uhvatite tijelo ventila. Ne hvatajte maticu koja brtvi servisni ventil

Cijevi na strani tekućine (manji promjer)

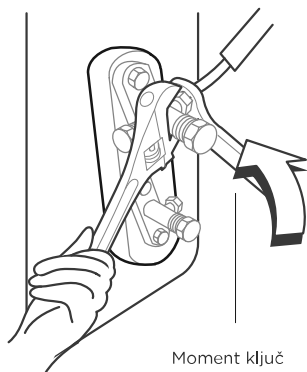

#### **! KORISTITE KLJUČ ZA HVATANJE TIJELA VENTILA**

Moment od zatezanja konusne matice može otkinuti druge dijelove ventila.

#### **Korak 3:**

- Čvrsto držeći tijelo ventila, pomoću moment ključa zategnite konusnu maticu prema točnim vrijednostima momenta.
- Lagano otpustite konusnu maticu, a zatim je ponovno zategnite.
- Ponovite korake od 1 do 3 za preostalu cijev

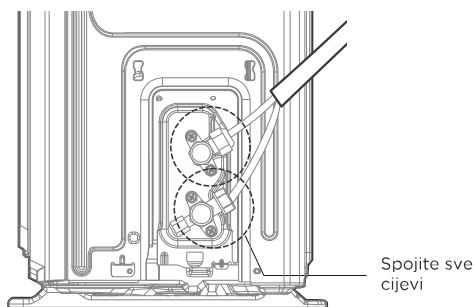

## Izbacivanje zraka

### **NAPOMENA: PRIPREME I MJERE OPREZA**

Zrak i strane tvari u krugu rashladnog sredstva mogu uzrokovati abnormalne poraste tlaka, što može oštetiti klima uređaj, smanjiti njegovu učinkovitost i uzrokovati ozljede. Upotrijebite vakuumsku pumpu i mjerac za pražnjenje kruga rashladnog sredstva, uklanjajući sav nekondenzirajući plin i vlagu iz sustava. Evakuaciju treba izvršiti nakon prve instalacije ili ako se jedinica premješta.

### **PRIJE PROVOĐENJA PRAŽNJENJA**

- ✓ Provjerite jesu li spojne cijevi između unutarnje i vanjske jedinice pravilno spojene.
- ✓ Provjerite je li sve ožičenje pravilno spojeno.

### Upute za pražnjenje

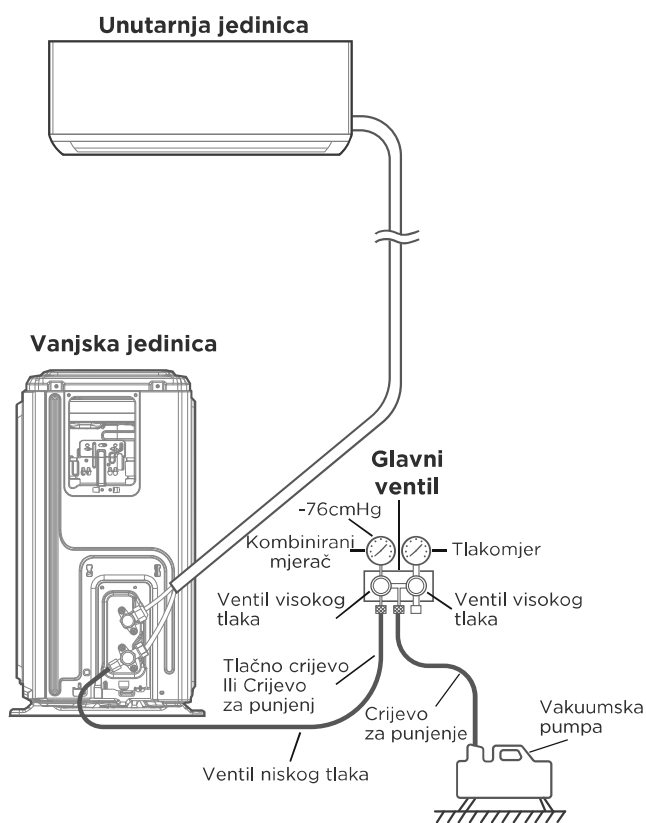

#### Korak 1:

- Spojite crijevo za punjenje tlakomjera na servisni priključak na niskotlačnom ventilu vanjske jedinice.
- Spojite drugo crijevo za punjenje od tlakomjera na vakuumsku pumpu.
- Otvorite niskotlačnu stranu tlakomjera. Držite visokotlačnu stranu zatvorenom. Uključite vakuumsku pumpu za pražnjenje sustava.
- Neka vakuumska pumpa radi najmanje 15 minuta ili dok mjerac spoja ne očita -76 cmHG (-10 Pa).
- Zatvorite niskotlačnu stranu tlakomjera i isključite vakuumsku pumpu. Pričekajte 5 minuta,

zatim provjerite da nije došlo do promjene tlaka u sustavu

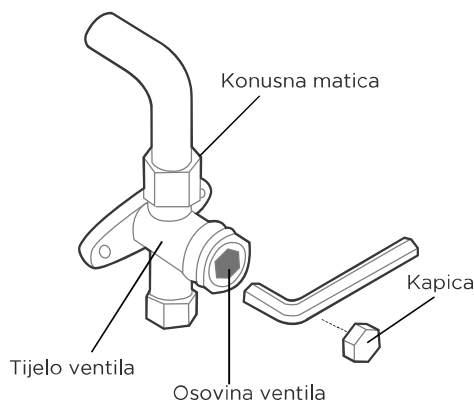

#### Korak 2:

- Ako je došlo do promjene tlaka u sustavu, pogledajte odlomak Provjera curenja plina za informacije o tome kako provjeriti ima li curenja.
- Ako nema promjene tlaka u sustavu, odvrnite kapicu s ventila (visokotlačni ventil). Umetnite šesterokutni ključ u ventil (visokotlačni ventil) i otvorite ventil okretanjem ključa za 1/4 okreta suprotno od kazaljke na satu. Oslušajte izlazi li plin iz sustava, zatim nakon 5 sekundi zatvorite ventil.
- Gledajte tlakomjer jednu minutu kako biste bili sigurni da nema promjena u tlaku. Tlakomjer treba prikazivati malo više od atmosferskog tlaka. Uklonite crijevo za punjenje iz servisnog priključka.
- Pomoću šesterokutnog ključa do kraja otvorite i visokotlačne i niskotlačne ventile.
- Zategnite kapice ventila na sva tri ventila (servisni priključak, visokotlačni i niskotlačni) rukom. Ako je potrebno, možete ga dodatno zategnuti pomoću moment ključa

## ! LAGANO OTVARAJTE OSOVINE VENTILA

Prilikom otvaranja osovine ventila, okrećite šesterokutni ključ dok ne udari o čep. Ne pokušavajte prisiliti ventil da se dalje otvori.

## 🔧 NAPOMENA O DODAVANJU RASHLADNOG SREDSTVA

Neki sustavi zahtijevaju dodatno punjenje ovisno o duljini cijevi. Standardna duljina cijevi ovisi o lokalnim propisima. Na primjer, u Sjevernoj Americi standardna duljina cijevi je 7,5 m (25'). U drugim područjima standardna duljina cijevi je 5 m (16'). Rashladno sredstvo treba puniti iz servisnog priključka na niskotlačnom ventilu vanjske jedinice. Dodatno rashladno sredstvo koje treba napuniti može se izračunati pomoću sljedeće formule:

## DODATNO RASHLADNO SREDSTVO PO DUŽINI CIJEVI

Dužina spojne cijevi (m)	Metoda pražnjenja zrak	Dodatno rashladno sredstvo	
< Stand. dužina cijevi	Vakim. pumpa	Vakim. pumpa	
> Standard dužina cijevi	Vakuumska pumpa	Strana tekućine: Ø 6.35 (1/4 ") R410A: (Dužina cijevi - stand. dužina) x 15g/m (Dužina cijevi - stand. dužina) x 0.16oZ/ft R32: (Dužina cijevi - stand. dužina) x 12g/m (Dužina cijevi - stand. dužina) x 0.13oZ/ft R22: (Dužina cijevi - stand. dužina) x 20g/m (Dužina cijevi - stand. dužina) x 0.21oZ/ft	Strana tekućine: Ø 9.52 R410A: (Dužina cijevi - stand. dužina) x 30g/m (Dužina cijevi - stand. dužina) x 0.32oZ/ft R32: (Dužina cijevi - stand. dužina) x 24g/m (Dužina cijevi - stand. dužina) x 0.26oZ/ft R22: (Dužina cijevi - stand. dužina) x 40g/m (Dužina cijevi - stand. dužina) x 0.42oZ/ft

## ⊘ NEMOJTE MIJEŠATI TIPOVE RASHLADNOG SREDSTVA

## Provjere elektrike i curenja plina

**⚠ UPOZORENJE-RIZIK OD ELEKTRIČNOG UDARA**  
SVO OŽIČENJE MORA BITI U SKLADU S LOKALNIM I NACIONALNIM ELEKTRIČNIM PROPISIMA I MORA IH INSTALIRATI LICENCIRANI ELEKTRIČAR.

### ! PRIJE PROBNOG RADA

Provedite probni rad tek nakon što ste proveli sljedeće korake:

- Provjere električne sigurnosti – Potvrdite da je električni sustav jedinice siguran i radi ispravno
- Provjere propuštanja plina – Provjerite sve spojeve s konusnom maticom i potvrdite da sustav ne propušta
- Provjerite jesu li ventili za plin i tekućinu (visoki i niski tlak) potpuno otvoreni

#### Provjere električne sigurnosti

Nakon instalacije, provjerite je li sve električno ožičenje postavljeno u skladu s lokalnim i nacionalnim propisima te u skladu s Priručnikom za instalaciju

#### PRIJE PROBNOG RADA

##### Provjerite uzemljenje

Izmjerite otpor uzemljenja vizualnom detekcijom i ispitivačem otpora uzemljenja

#### TIJEKOM PROBNOG RADA

##### Provjerite električni proboj

Tijekom probnog rada koristite elektrosondu i multimetar za izvođenje opsežnog testa električnog proboja.

Ako se otkrije električni proboj, odmah isključite jedinicu i pozovite ovlaštenog električara da pronađe i riješi uzrok proboja

**Napomena:** ovo možda nije potrebno za neke lokacije u Sjevernoj Americi.

#### Provjere curenja plina

Postoje dvije različite metode za provjeru curenja plina

##### Metoda sa sapunom i vodom

Pomoću meke četke nanesite sapunicu ili tekući deterdžent na sve spojne točke cijevi na unutarnjoj i vanjskoj jedinici. Prisutnost mjehurića ukazuje na curenje.

##### Metoda detektora curenja

Ako koristite detektor curenja, upute za ispravnu uporabu potražite u priručniku za uporabu uređaja

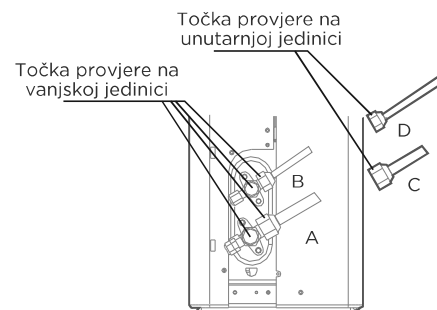

A. Niskotlačni stop ventil  
B. Visokotlačni stop ventil  
C & D: Konusne matice unutarnje jedinice

## NAKON PROVJERE CURENJA PLINA

Nakon što se uvjerite da sve spojne točke cijevi NE propuštaju, vratite poklopac ventila na vanjsku jedinicu.



## Probni rad

### Upute za probni rad

Probni rad bi trebali provesti barem 30 minuta.

- Spojite napajanje jedinice.
- Pritisnite tipku ON/OFF na daljinskom upravljaču kako biste ju uključili.
- Pritisnite tipku MODE za pomicanje kroz sljedeće funkcije, jednu po jednu
  - COOL—odaberite najnižu moguću temperaturu
  - GRIJANJE—Odaberite najvišu moguću temperaturu
- Neka svaka funkcija radi 5 minuta i izvršiti sljedeće provjere:

Popis provjera	PROŠAO/NIJE PROŠAO	
Nema električnog proboja		
Jedinica je pravilno uzemljena		
Svi električni priključci su pravilno pokriveni		
Unutarnja i vanjska jedinica su čvrsto ugrađene		
Svi spojevi cijevi ne propuštaju	Vanjska (2):	Unutarnja (2):
Voda pravilno izlazi iz drenažnog crijeva		
Sve cijevi su pravilno izolirane		
Jedinica pravilno provodi COOL funkciju		
Jedinica pravilno provodi HEAT funkciju		
Zaklopke unutarnje jedinice se pravilno pomiču		
Unutarnja jedinica reagira na daljinski upravljač		

## PONOVA PROVJERA SPOJEVA CIJEVI

Tijekom rada, tlak u krugu rashladnog sredstva će se povećati. Ovo može otkriti curenje koje nije postojalo tijekom vaše prve provjere curenja. Odvojite vrijeme tijekom probnog rada kako biste još jednom provjerili da sve spojne točke cijevi rashladnog sredstva ne propuštaju. Za upute pogledajte odlomak Provjera curenja plina.

- Nakon što je probni rad uspješno dovršen i provjere da su sve točke provjere na popisu provjera PROŠLE, učinite sljedeće:
  - a. Pomoću daljinskog upravljača vratite jedinicu na normalnu radnu temperaturu.
  - b. Pomoću izolacijske trake omotajte spojeve cijevi rashladnog sredstva unutarnje jedinice koje ste ostavili nezamotane tijekom postupka instalacije unutarnje jedinice.

### AKO JE TEMPERATURA OKOLINE ISPOD 16°C (60°F)

Ne možete koristiti daljinski upravljač za prebacivanje na funkciji COOL kada je temperatura okoline ispod 16°C/62°F. U ovom slučaju možete koristiti tipku **MANUAL CONTROL** za testiranje funkcije COOL.

- Podignite prednju ploču unutarnje jedinice i podignite je dok ne klikne na mjesto.
- Tipka **MANUAL CONTROL** nalazi se na desnoj strani jedinice. Pritisnite 2 puta za odabir funkcije COOL.
- Provedite probni rad kao i običn

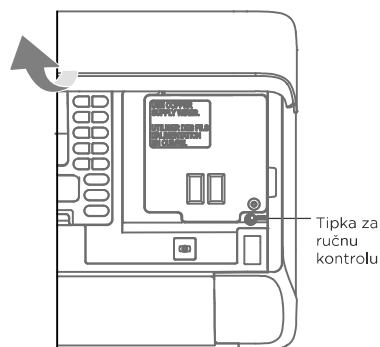

## Pakiranje i raspakiranje jedinice

### Upute za pakiranje i raspakiranje jedinice:

#### Raspakiranje:

##### Unutarnja jedinica:

1. Izrežite nožem brtvenu traku na kutiji, jedan rez na lijevoj strani, jedan rez u sredini i jedan rez na desnoj strani
2. Pomoću kliješta izvadite brtvene čavle na vrhu kutije.
3. Otvorite kutiju.
4. Izvadite srednju potpornu ploču ako je uključena.
5. Izvadite paket dodatne opreme i izvadite spojnu žicu ako je uključena.
6. Podignite uređaj iz kutije i položite ga ravno.
7. Uklonite lijevu i desnu pjenu za pakiranje ili gornju i donju pjenu za pakiranje, odvežite vrećicu za pakiranje.

##### Vanjska jedinica

1. Izrežite remen za pakiranje.
2. Izvadite jedinicu iz kutije.
3. Uklonite pjenu s jedinice.
4. Uklonite vrećicu za pakiranje s jedinice.

#### Pakiranje:

##### Unutarnja jedinica:

1. Stavite unutarnju jedinicu u vreću za pakiranje.
2. Pričvrstite lijevu i desnu pjenu za pakiranje ili gornju i donju pjenu za pakiranje na jedinicu.
3. Stavite jedinicu u kartonsku kutiju, a zatim stavite paket dodatne opreme.
4. Zatvorite kutiju i zalijepite je trakom.
5. Koristite traku za pakiranje ako je potrebno.

##### Vanjska jedinica:

1. Stavite vanjsku jedinicu u vreću za pakiranje.
2. Stavite donju pjenu u kutiju.
3. Stavite jedinicu u kutiju, zatim stavite gornju pjenu za pakiranje na jedinicu.
4. Zatvorite kutiju i zalijepite je trakom.
5. Koristite traku za pakiranje ako je potrebno.

**NAPOMENA:** Sačuvajte sve stavke pakiranja ako vam zatrebaju u budućnosti.





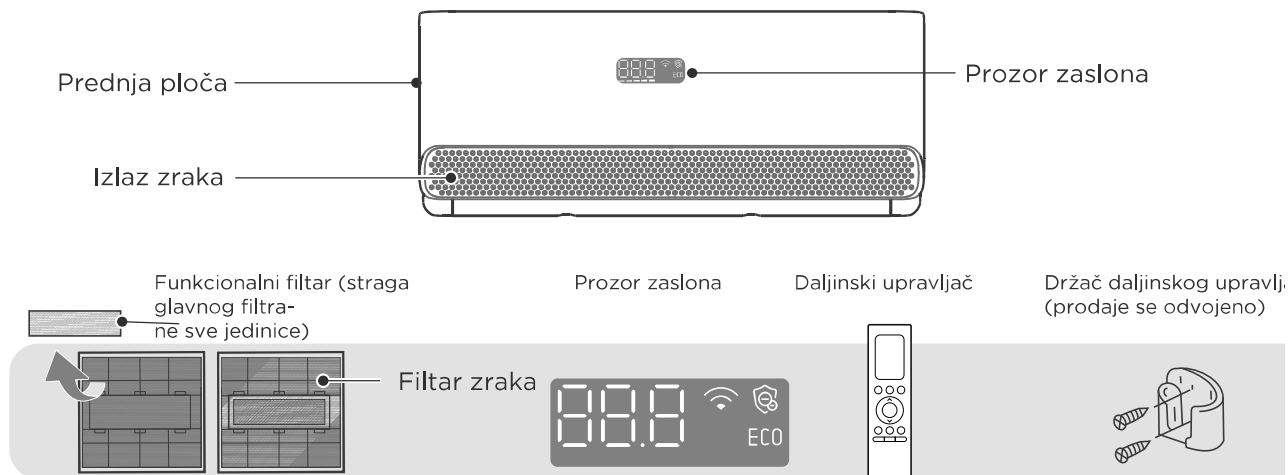

# UPUTE ZA UPORABU

## NAPOMENA

- Različiti modeli imaju različite prednje ploče i prozor zaslona. Neke značajke opisane u nastavku možda neće biti primjenjive na klima uređaj koji ste kupili. Provjerite unutarnji prozor jedinice koju ste kupili.
- Ilustracije u ovom priručniku služe u svrhu objašnjenja. Stvarni oblik vaše unutarne jedinice može biti malo drugačiji.

## Zaslon unutarnje jedinice



Prikazani kod	Značenje prikazanog koda
888	<ul style="list-style-type: none"> <li>• Prikazuje temperaturu, radnu funkciju i kodove pogrešaka</li> </ul>
	<ul style="list-style-type: none"> <li>• Kada je aktivirana funkcija bežičnog upravljanja</li> </ul>
	<ul style="list-style-type: none"> <li>• Kada je aktivirana funkcija Air magic ili UV-C lampe (ako postoji)</li> </ul>
ECO	<ul style="list-style-type: none"> <li>• Kada je aktivirana ECO funkcija</li> </ul>
 (na 3s kada )	<ul style="list-style-type: none"> <li>• TIMER ON je postavljen (ako je jedinica ISKLJUČENA, “ON” ostaje uključeno kada je postavljen TIMER ON)</li> <li>• UV-C lampa, funkcije Fresh, Brezzeless, SWING, TURBO ili SILENT su uključene.</li> </ul>
 (na 3s kada )	<ul style="list-style-type: none"> <li>• TIMER OFF je postavljen.</li> <li>• UV-C lampa, funkcije Fresh, Brezzeless, SWING, TURBO ili SILENT su isključene.</li> </ul>
	<ul style="list-style-type: none"> <li>• Prilikom odmrzavanja (jedinice za hlađenje i grijanje)</li> </ul>
	<ul style="list-style-type: none"> <li>• Kada je uključena aktivna funkcija čišćenja</li> </ul>
	<ul style="list-style-type: none"> <li>• Kada je uključen način grijanja na 8°C (46°F)</li> </ul>

## Radna temperatura

Kada se vaš klima uređaj koristi izvan sljedećih temperaturnih raspona, određene sigurnosne zaštitne značajke mogu se aktivirati i uzrokovati prekid rada jedinice.

### Inverterski split tip

	COOL način	HEAT način	DRY način
Sobna temp	16°C ~ 32°C (60°F ~ 90°F)	0°C ~ 30°C (32°F ~ 86°F)	10°C ~ 32°C (50°F ~ 90°F)
Vanjska temp	0°C ~ 50°C (32°F ~ 122°F)		
	-15°C ~ 50°C (5°F ~ 122°F) Za modele se nisko-temperaturnim sustavima hlađenja	-15°C ~ 24°C (5°F ~ 75°F)	0°C ~ 50°C (32°F ~ 122°F)
	-15°C ~ 50°C (5°F ~ 122°F) Za posebne tropske modele	-15°C ~ 24°C (5°F ~ 75°F)	0°C ~ 52°C (32°F ~ 126°F) Za posebne tropske modele

### ZA VANJSKE JEDINICE S POMOĆNIM ELEKTRIČNIM GRIJAČEM

Kada je vanjska temperatura ispod 0°C (32°F), toplo preporučamo da jedinica ostane stalno uključena u struju kako bi se osigurao nesmetan rad

#### Tip s fiksnom brzinom

	COOL način	HEAT način	DRY način
Sobna temp	16°C ~ 32°C (60°F ~ 90°F)	0°C ~ 30°C (32°F ~ 86°F)	10°C ~ 32°C (50°F ~ 90°F)
Vanjska temp	18°C ~ 43°C (64°F ~ 109°F)		11°C ~ 43°C (52°F ~ 109°F)
	-7°C ~ 43°C (19°F ~ 109°F) Za modele se nisko-temperaturnim sustavima hlađenja	-7°C ~ 24°C (19°F ~ 75°F)	18°C ~ 43°C (64°F ~ 109°F)
	18°C ~ 52°C (64°F ~ 126°F) Za posebne tropske modele	-15°C ~ 24°C (5°F ~ 75°F)	18°C ~ 52°C (64°F ~ 126°F) Za posebne tropske modele

**NAPOMENA:** Ako klima uređaj radi kada je relativna vlažnost u prostoriji veća od 80%, površina klima uređaja može privući kondenzaciju. Postavite zaklopke za vertikalni protok zraka na maksimalni kut (okomito u odnosu na pod) i postavite način rada ventilatora na HIGH

## Za dodatno optimiziranje performansi vaše jedinice, učinite sljedeće:

- Držite vrata i prozore zatvorenima.
- Ograničite potrošnju energije korištenjem funkcija TIMER ON i TIMER OFF.
- Nemojte blokirati ulaze ili izlaze zraka.
- Redovito provjeravajte i čistite filtre zraka

## Više značajki

- **Automatsko ponovno pokretanje**  
Ako jedinica izgubi napajanje, automatski će se ponovno pokrenuti s prethodnim postavkama nakon ponovnog uspostavljanja napajanja.
- **Zaštita od plijesni (ne sve jedinice)**  
Kada isključite jedinicu iz načina HLAĐENJA, AUTO (COOL) ili SUŠENJA, klima uređaj će nastaviti raditi na vrlo maloj snazi i isušivati kondenziranu vodu te sprječavati nastanak plijesni.
- **Bežično upravljanje (ovisno o modelu)**  
Bežično upravljanje omogućuje vam upravljanje klima uređajem putem mobilnog telefona i bežične veze.  
Pristup USB uređaju, zamjena dijelova i radnje održavanja mora obavljati kvalificirano osoblje.
- **Funkcija Active Clean (ne sve jedinice)**  
-Active Clean tehnologija ispire prašinu kada se zaljepi za izmjenjivač topline automatskim smrzavanjem i zatim brzim odmrzavanjem leda. Čut će se zvuk "bip-bip". Operacija aktivnog čišćenja koristi se za proizvodnju više kondenzirane vode kako bi se poboljšao učinak čišćenja, a hladni zrak će ispuhati. Nakon čišćenja, unutarnji ventilator nastavlja raditi s vrućim zrakom kako bi osušio isparivač, čime se unutrašnjost održava čistom.  
-Kada je ova funkcija uključena, prozor unutarnje jedinice prikazuje "CL", nakon 20 do 130 minuta, jedinica će se automatski isključiti i prekinuti funkciju Active Clean.  
-Za neke jedinice, sustav će pokrenuti proces čišćenja visokom temperaturom i temperatura zraka koji izlazi može biti vrlo visoka. Molimo držite se na udaljenosti. To će vjerojatno dovesti do povećanja sobne temperature.
- **Memorija kuta zaklopki**  
Kada uključite jedinicu, zaklopke će automatski vratiti svoj prethodni kut.
- **Air Magic+ funkcija (ne sve jedinice)**  
Vanjski emiter s dvostrukom cijevi proizvodi električno polje za stvaranje milijuna negativnih iona. Super val negativnih iona pročišćava zrak u prostoriji.
- **Cool Flash funkcija**  
Cool Flash tehnologija može vrlo brzo ohladiti cijelu prostoriju. To se postiže proizvodnjom velikog volumena zraka i velikim protokom zraka.
- **Heat Flash funkcija**  
Slično, brz i snažan protok zagrijanog zraka može zagrijati cijelu prostoriju u kratkom vremenu.
- **Detekcija curenja rashladnog sredstva**  
Unutarnja jedinica će automatski prikazati "ELOC" kada otkrije curenje rashladnog sredstva.
- **Funkcija UV-C lampe (ne sve jedinice)**  
Kada se pokrene funkcija UV lampe, UV lampa emitira UV-C zračenje kako bi pomogla u pročišćavanju zraka u unutrašnjosti.
- **Funkcija bez povjetarca**  
-Revolucionarni dvostruki deflektori mogu promijeniti, preusmjeriti i raspršiti strujanje zraka. Protok zraka može se ublažiti do željene razine.  
-Uživajte u svježem, hladnom zraku s onoliko puno ili malo direktnog povjetarca koliko želite.  
-Deflektor se sastoji od tisuća mini-rupa koje mogu transformirati snažan protok zraka u tisuće sićušnih struja zraka dajući vam suptilan osjećaj hlađenja
- **Rad bez povjetarca**  
Klima uređaj će automatski prilagoditi kut zaklopki i brzinu ventilatora na temelju sobne temperature i vlažnosti. Postoje četiri različita radna stanja, vidi sl. 1-4.

Povjetarac se širi

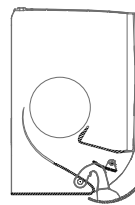

SI. 1

Blagi povjetarac

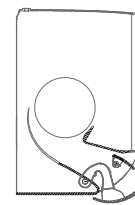

SI. 2

Bez povjetarca

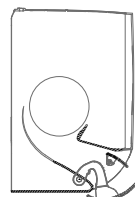

SI. 3

Bez povjetarca

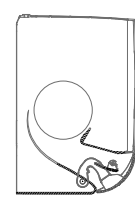

SI. 4

**NAPOMENA:** Za prostorije koje zahtijevaju puno hlađenja ili ako je vanjska temperatura vrlo visoka, ne preporučuje se rad bez povjetarca, jer to može uzrokovati nelagodu

- **Sleep funkcija**

Funkcija SLEEP koristi se za smanjenje potrošnje energije dok spavate (tijekom ciklusa spavanja tijela potrebno je manje hlađenja ili grijanja). Pritisnite tipku SLEEP na daljinskom upravljaču kada ste u načinu COOL. Jedinica će povećati temperaturu za 1°C (2°F) nakon prvog sata. Povećat će se za dodatnih 1°C (2°F) nakon još sat vremena. Brzina ventilatora se automatski podešava na LOW.

Kada je u načinu rada HEAT, funkcija SLEEP će smanjiti temperaturu za 1°C (2°F) nakon prvog sata. Snizit će temperaturu za dodatnih 1°C

(2°F) nakon još jednog sata. Brzina ventilatora se automatski podešava na LOW. Tada će klima uređaj raditi na novoj temperaturi još šest sati. Nakon toga, funkcija SLEEP će se zaustaviti, brzina ventilatora će se vratiti na izvornu postavku

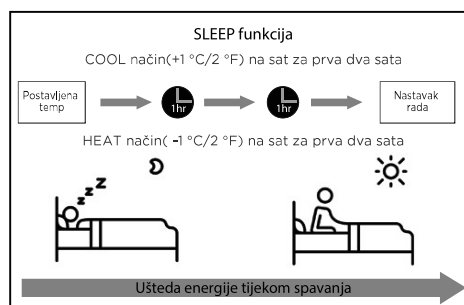

## Postavljanje kuta protoka zraka

### **NAPOMENA: POSTAVLJANJE KUTA PROTOKA ZRAKA (DALJINSKI UPRAVLJAČ)**

Dok je jedinica uključena, koristite tipku SWING na daljinskom upravljaču za postavljanje smjera (okomiti/vodoravni kut) protoka zraka. Za više detalja pogledajte odlomak Rad daljinskog upravljača

### **NAPOMENA O KUTOVIMA ZAKLOPKE**

- Ne postavljajte zaklopke pod previše okomitim kutom na duže vrijeme kada koristite način COOL ili DRY. Na zaklopki će se stvoriti kondenzacija koja će kapati na pod ili namješta.
- Postavljanje zaklopke pod premalim kutom kada koristite način COOL ili HEAT može smanjiti performanse klima uređaja zbog ograničenog protoka zraka.
- U skladu sa zahtjevima odgovarajućih normi, postavite ventilaciju za vertikalni protok zraka na maksimalni kut tijekom ispitivanja kapaciteta grijanja.

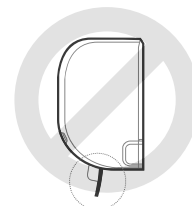

### **NAPOMENA**

Ne pomičite zaklopke rukom. To će uzrokovati da zaklopka ne bude sinkronizirana. Ako se to dogodi, isključite jedinicu i odspojite je od napajanja na nekoliko sekundi, a zatim ponovno pokrenite jedinicu. Ovo će resetirati zaklopku.

## **⚠ OPREZ**

Nemojte stavljati prste u ili u blizinu puhala i usisne strane jedinice. Ventilator velike brzine unutar jedinice može uzrokovati ozljede.

### **Ručni način rada (bez daljinskog upravljača)**

#### **⚠ OPREZ: ZA UPORABU PROIZVODA**

Tipka za ručni način rada namijenjena je samo za potrebe testiranja i hitnog rada. Nemojte koristiti ovu funkciju osim ako ste izgubili daljinski upravljač, a to je prije potrebno. Za vraćanje redovnog rada, koristite daljinski upravljač za aktiviranje jedinice. Prije ručnog rada, jedinica mora biti isključena.

#### **Za ručnu uporabu jedinice:**

- Otvorite prednju ploču unutarnje jedinice.
- Pronađite tipku **MANUAL CONTROL** na desnoj strani jedinice.
- Pritisnite tipku **MANUAL CONTROL** jednom za aktiviranje PRISILNOG AUTOMATSKOG načina rada.
- Pritisnite tipku **MANUAL CONTROL** drugi put za aktiviranje načina PRISILNO HLAĐENJE.
- Pritisnite tipku **MANUAL CONTROL** treći put kako biste isključili jedinicu.
- Zatvorite prednju ploču

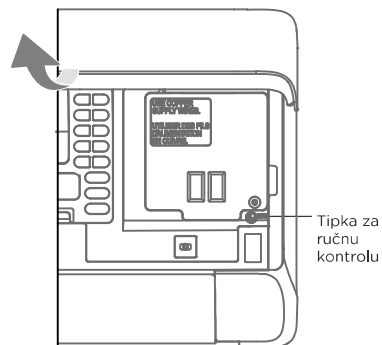

## Uporaba daljinskog upravljača

### Vodič za brzi početak

1 UBACITE BATERIJE

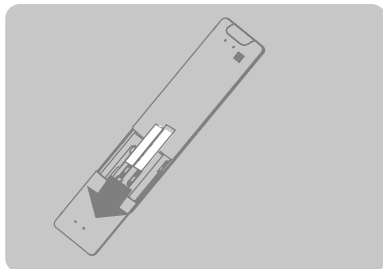

2 ODABERITE NAČIN RADA

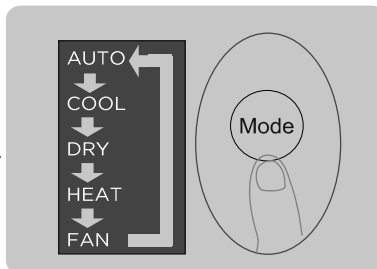

3 ODABERITE TEMPERATURU

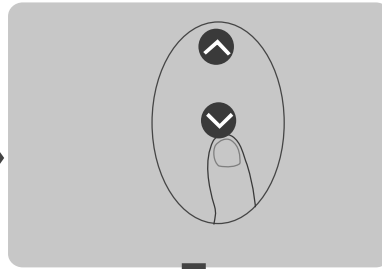

6 PRITISNITE ON/OFF TIPKU

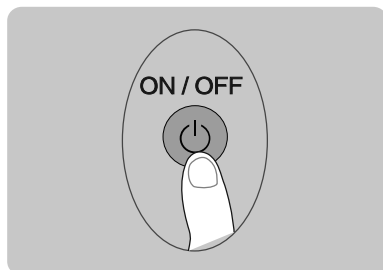

5 USMJERITE UPRAVLJAČ PREMA JEDINICI

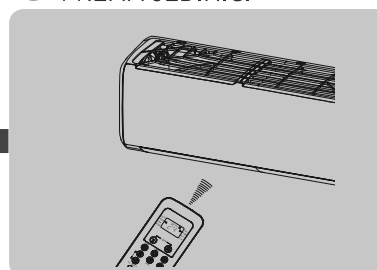

4 ODABERITE BRZINU PUHALA

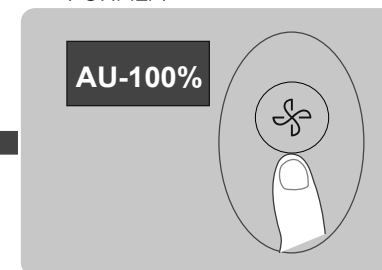

### OBJAŠNENJE FUNKCIJE

Pogledajte odlomke Kako koristiti osnovne funkcije i Kako koristiti napredne funkcije ovog priručnika za detaljniji opis kako koristiti svoj klima uređaj.

### POSEBNA NAPOMENA:

- Dizajn tipki na vašoj jedinici može se malo razlikovati od prikazanog primjera.
- Ako unutarnja jedinica nema određenu funkciju, pritiskanje tipke te funkcije na daljinskom upravljaču neće imati učinka.



## Rukovanje daljinskim upravljačem

### Ubacivanje i zamjena baterija

Vaš klima uređaj može doći s dvije baterije (ne sve jedinice). Prije upotrebe stavite baterije u daljinski upravljač.

1. Gurnite stražnji poklopac daljinskog upravljača prema dolje, otkrivajući pretinac za baterije.
2. Umetnite baterije, pazeći da se polovi (+) i (-) baterija podudaraju sa simbolima unutar odjeljka za baterije.
3. Gurnite poklopac baterije natrag na mjesto

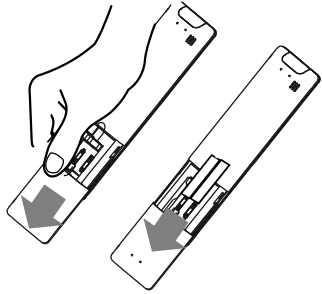

### NAPOMENE O BATERIJAMA

Za optimalne performanse proizvoda:

- Nemojte miješati stare i nove baterije ili različite marke baterija.
- Ne ostavljajte baterije u daljinskom upravljaču ako ne planirate koristiti uređaj dulje od 2 mjeseca

### ZBRINJAVANJE BATERIJA

Nemojte zbrinjavati baterije u uobičajeni kućni otpad. Za pravilno odlaganje baterija pogledajte lokalne zakone.

### NAPUTCI ZA UPORABU DALJINSKOG UPRAVLJAČA

- Daljinski upravljač se mora koristiti unutar 8 metara od jedinice.
- Jedinica će se oglasiti zvučnim signalom kada primi daljinski signal.
- Zavjese, drugi materijali i direktna sunčeva svjetlost mogu ometati prijemnik infracrvenog signala.
- Izvadite baterije ako daljinski upravljač nećete koristiti dulje vrijeme

### NAPOMENE O UPORABI DALJINSKOG UPRAVLJAČA

Uređaj može biti u skladu s lokalnim nacionalnim propisima.

- U Kanadi bi trebao biti u skladu s CAN ICES-3(B)/NMB-3(B).
- U SAD-u ovaj je uređaj u skladu s dijelom 15 FCC pravila. Rad je podložan sljedećim uvjetima:
  - a. Ovaj uređaj ne smije uzrokovati štetne smetnje i
  - b. ovaj uređaj mora prihvatiti sve primljene smetnje, uključujući smetnje koje mogu uzrokovati neželjeni rad.







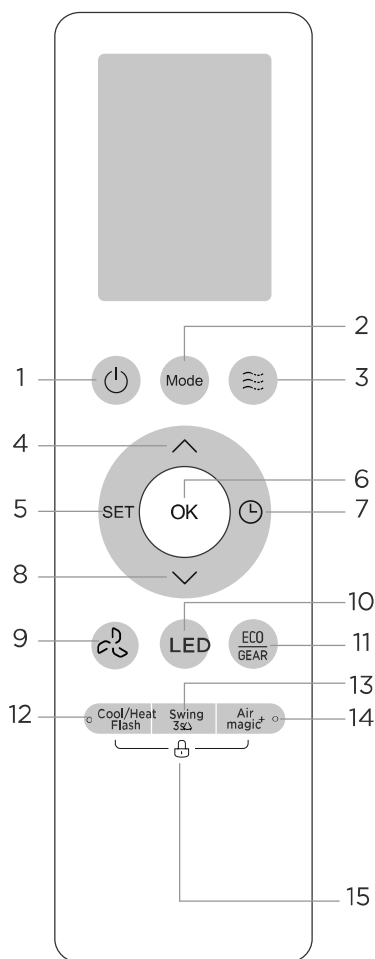











Ova je oprema testirana i utvrđeno je da je u skladu s ograničenjima za digitalne uređaje klase B, u skladu s dijelom 15 FCC pravila. Ova su ograničenja osmišljena kako bi pružila razumnu zaštitu od štetnih smetnji u stambenim instalacijama. Ova oprema generira, koristi i može zračiti radiofrekventnu energiju i, ako se ne instalira i koristi u skladu s uputama, može uzrokovati štetne smetnje radijskim komunikacijama. Međutim, nema jamstva da se smetnje neće pojaviti u određenoj instalaciji. Ako ova oprema uzrokuje štetne smetnje radijskom ili televizijskom prijemu, što se može utvrditi isključivanjem i uključivanjem opreme, korisnik se potiče da pokuša ispraviti smetnje pomoću jedne ili više sljedećih mjera:

- Preusmjerite ili premjestite prijemnu antenu.
- Povećajte razmak između opreme i prijemnika.
- Spojite opremu u utičnicu na strujnom krugu različitom od onog na koji je spojen prijemnik.
- Obratite se prodavaču ili iskusnom radio/TV tehničaru za pomoć.
- Promjene ili modifikacije koje nije odobrila strana odgovorna za sukladnost mogu poništiti korisnikovo ovlaštenje za rukovanje opremom

## Tipke i funkcije

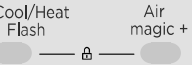

Model A

Opis	
Br.1	 <b>ON/OFF</b> Uključuje/isključuje jedinicu
Br.2	 <b>NAČIN RADA</b> Auto > Cool > Dry > Heat > Fan <b>NAPOMENA:</b> HEAT način rada ne podržavaju jedinice koje samo hlade
Br.3	 <b>POVJETARAC</b> Breezeless > Breeze away > Breeze mild > Stop
Br.4	 <b>TEMP.</b> Povećava temperaturu u koracima od 0.5°C (1°F). Maks. temperatura je 30°C (86°F). (Istovremeno pritisnite tipke  i  na 3 sekunde za promjenu prikaza temperature između °C & °F).
Br.5	 <b>SET</b> Active clean > Sleep > Follow Me > AP mode > Active clean
Br.6	 <b>OK</b> Koristi se za potvrdu odabranih funkcija
Br.7	 <b>TEMP.</b> Postavljanje tajmera za uklj/isklj jedinice
Br.8	 <b>TEMP.</b> Smanjuje temperaturu u koracima od 0.5°C (1°F). Min. temperatura je 16°C (60°F)
Br.9	 <b>BRZINA PUHALA</b> <b>AU &gt; 20% &gt; 40% &gt; 60% &gt; 80% &gt; 100%</b> Pritisnite TEMP tipke  i  za povećanje/smanjenje brzine ventilatora u koracima od 1%.
Br.10	 <b>LED</b> Uklj/isklj Led zaslona i zvučnog signala uređaja
Br.11	 <b>ECO/GEAR</b> ECO > GEAR(75%) > GEAR(50%) > Prethodni način rada > ECO
Br.12	 <b>Cool/Heat Flash</b> Smanjenje (COOL način) ili povećanje (HEAT način) temperature u kratkom vremenu
Br.13	 <b>ZAKLOPKA</b> Započinje i zaustavlja vodoravno kretanje zaklopke. Držite 3 sekunde za početak automatskog okomitog kretanja zaklopke (neke jedinice)
Br.14	 <b>Air magic+</b> Koristi se za pokretanje/zaustavljanje funkcije Air magic i UV-C lampe (ako postoji)
Br.15	 <b>ZAKLJUČAVANJE</b> Istovremeno pritisnite ova dvije tipke na 5 sekundi kako biste zaključali tipke. Pritisnite zajedno ove dvije tipke na 2 sekunde za otključavanje tipki.

## Tipke i funkcije

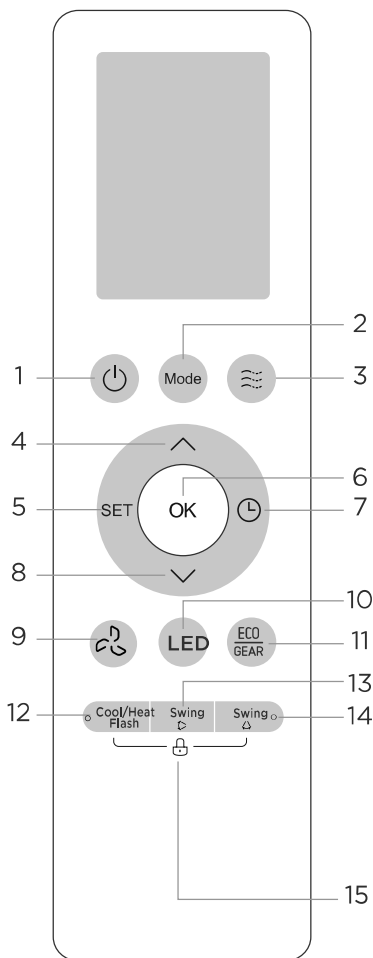







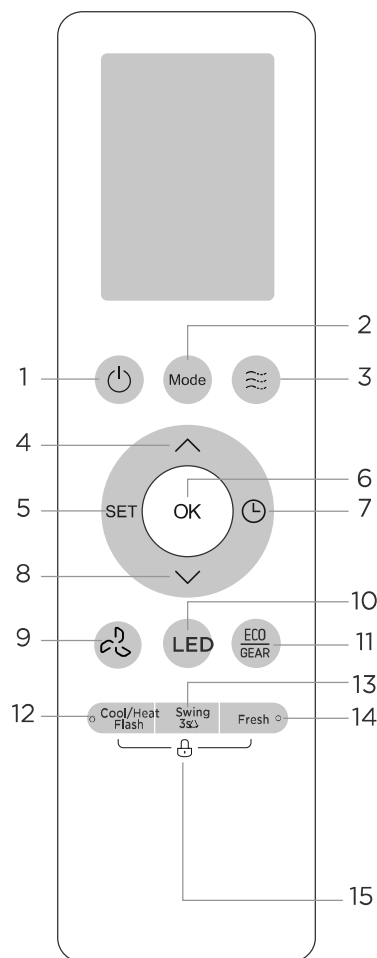













Model B

Opis	
Br.1	<b>ON/OFF</b> Uključuje/isključuje jedinicu
Br.2	<b>NAČIN RADA</b> Auto > Cool > Dry > Heat > Fan <b>NAPOMENA:</b> HEAT način rada ne podržavaju jedinice koje samo hlade
Br.3	<b>POVJETARAC</b> Breezeless > Breeze away > Breeze mild>Stop
Br.4	<b>TEMP.</b> Povećava temperaturu u koracima od 0,5°C (1°F). Maks. temperatura je 30°C (86°F). (Istovremeno pritisnite tipke  i  na 3 sekunde za promjenu prikaza temperature između °C & °F).
Br.5	<b>SET</b> Active clean > Sleep > Follow Me > AP mode* > Active clean [*]: Ovisno o modelu
Br.6	<b>OK</b> Koristi se za potvrdu odabranih funkcija
Br.7	<b>TEMP.</b> Postavljanje tajmera za uklj/isklj jedinice
Br.8	<b>TEMP.</b> Smanjuje temperaturu u koracima od 0,5°C (1°F). Min. temperatura je 16°C (60°F)
Br.9	<b>BRZINA PUHALA</b> <b>AU &gt; 20% &gt;40% &gt;60% &gt; 80% &gt; 100%</b> Pritisnite TEMP tipke  i  za povećanje/smanjenje brzine ventilatora u koracima od 1%.
Br.10	<b>LED</b> Uklj/isklj Led zaslona i zvučnog signala uređaja
Br.11	<b>ECO/GEAR</b> ECO > GEAR(75%) > GEAR(50%) > Prethodni način rada > ECO
Br.12	<b>Cool/Heat Flash</b> Smanjenje (COOL način) ili povećanje (HEAT način) temperature u kratkom vremenu
Br.13	<b>ZAKLOPKA (gore i dolje)</b> Započinje i zaustavlja vodoravno kretanje zaklopke. Držite 2 sekunde za početak automatskog vodoravnog kretanja zaklopke (neke jedinice)
Br.14	<b>ZAKLOPKA (lijevo i desno)</b> Započinje i zaustavlja okomito kretanje zaklopke
Br.15	<b>ZAKLJUČAVANJE</b> Istovremeno pritisnite ova dvije tipke na 5 sekundi kako biste zaključali tipke. Pritisnite zajedno ove dvije tipke na 2 sekunde za otključavanje tipki

## Tipke i funkcije



Model C

Opis	
Br.1	 <b>ON/OFF</b> Uključuje/isključuje jedinicu
Br.2	 <b>MODE</b> Auto > Cool > Dry > Heat > Fan <b>NAPOMENA:</b> HEAT način rada ne podržavaju jedinice koje samo hlade
Br.3	 <b>POVJETARAC</b> Breezeless > Breeze away > Breeze mild>Stop
Br.4	 <b>TEMP.</b> Povećava temperaturu u koracima od 0.5°C (1°F). Maks. temperatura je 30°C (86°F). (Istovremeno pritisnite tipke  i  na 3 sekunde za promjenu prikaza temperature između °C & °F).
Br.5	 <b>SET</b> Active clean > Sleep > Follow Me > AP mode* > Active clean [*]: Ovisno o modelu
Br.6	 <b>OK</b> Koristi se za potvrdu odabranih funkcija
Br.7	 <b>TEMP.</b> Postavljanje tajmera za uklj/isklj jedinice
Br.8	 <b>TEMP.</b> Smanjuje temperaturu u koracima od 0.5°C (1°F). Min. temperatura je 16°C (60°F)
Br.9	 <b>FAN SPEED</b> <b>AU &gt; 20% &gt; 40% &gt; 60% &gt; 80% &gt; 100%</b>  tis  e TEMP tipke i za povećanje/smanjenje brzine ventilatora u koracima od 1%.
Br.10	 <b>LED</b> Uklj/isklj Led zaslona i zvučnog signala uređaja
Br.11	 <b>ECO/GEAR</b> ECO > GEAR(75%) > GEAR(50%) > Prethodni način rada > ECO
Br.12	 <b>Cool/Heat Flash</b> Smanjenje (COOL način) ili povećanje (HEAT način) temperature u kratkom vremenu
Br.13	 <b>ZAKLOPKA</b> Započinje i zaustavlja vodoravno kretanje zaklopke. Držite 3 sekunde za početak automatskog okomitog kretanja zaklopke (neke jedinice)
Br.14	 <b>FRESH</b> Započinje i zaustavlja funkciju UV-C lampe
Br.15	  <b>ZAKLJUČAVANJE</b> Istovremeno pritisnite ova dvije tipke na 5 sekundi kako biste zaključali tipke. Pritisnite zajedno ove dvije tipke na 2 sekunde za otključavanje tipki

## Indikatori na zaslonu daljinskog upravljača

Prikazane informacije kada se daljinski upravljač uključi.

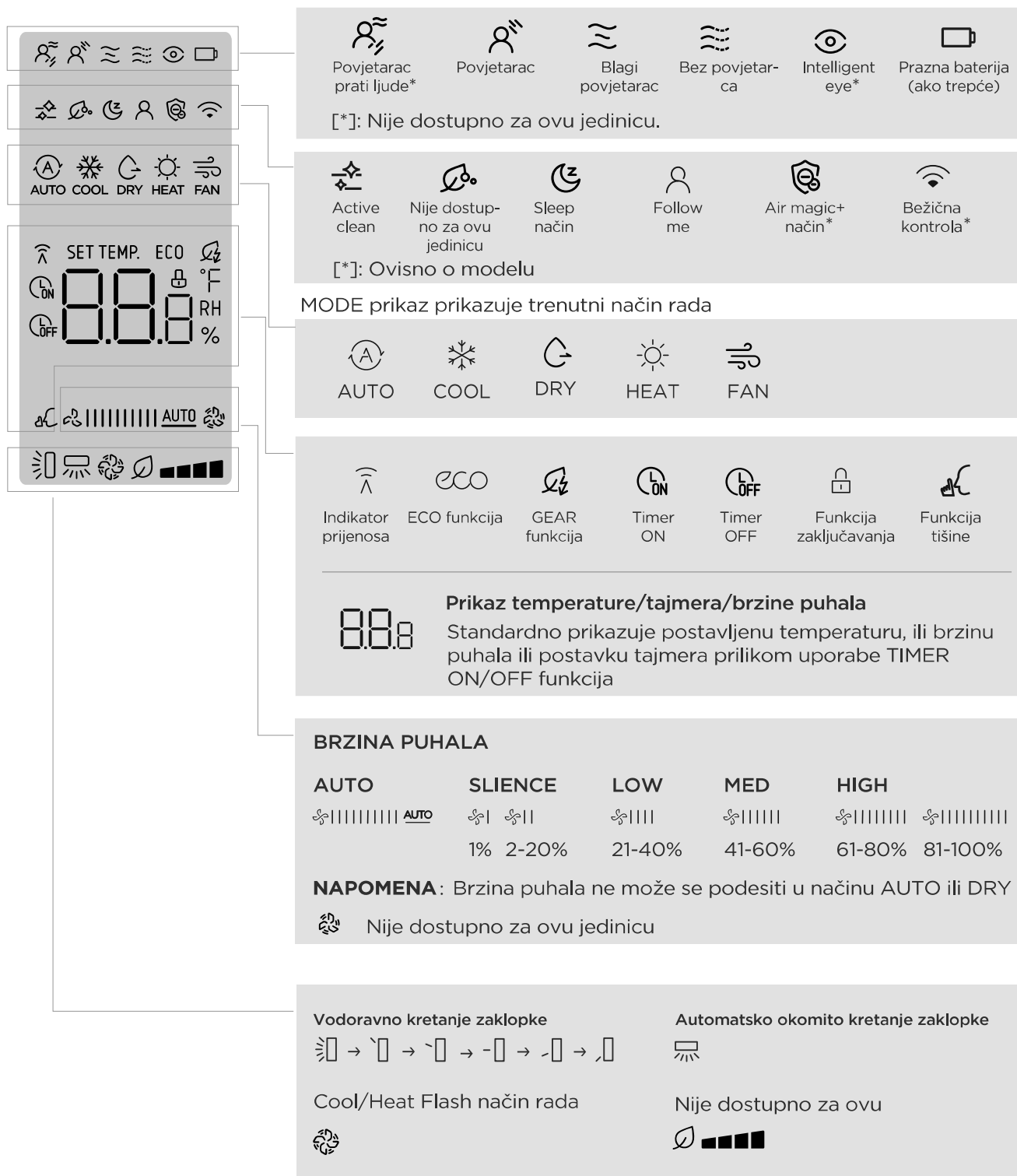

### NAPOMENA

1. Svi gore navedeni indikatori služe u informativne svrhe. Tijekom stvarnog rada, na zaslonu će biti prikazani samo odgovarajući indikatori.

## Kako koristiti osnovne funkcije

### **NAPOMENA**

Prije uporabe provjerite je li jedinica spojena na napajanje i postoji li napajanje.

#### **AUTO način rada**

Odaberite AUTO način

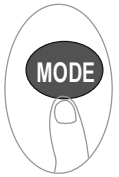

Postavite željenu temperaturu

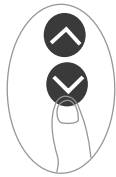

Uključite klima uređaj



#### **NAPOMENA:**

1. U AUTO načinu rada, jedinica će automatski odabrati funkciju COOL, FAN ili HEAT na temelju odabrane temperature
2. U AUTO načinu rada, brzina ventilatora se ne može postaviti.

#### **COOL ili HEAT način rada**

Odaberite COOL/HEAT način

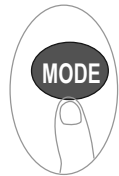

Postavite temperaturu

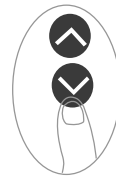

Postavite brzinu ventilatora



Uključite klima uređaj

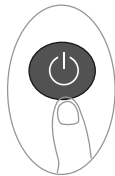

#### **DRY način rada**

Odaberite DRY način

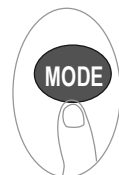

Postavite željenu temperaturu



Uključite klima uređaj



**NAPOMENA:** U DRY načinu rada, brzina puhalo ne može se postaviti jer se već kontrolira automatski

#### **FAN način rada**

Odaberite FAN način

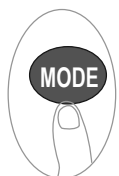

Postavite brzinu ventilatora



Uključite klima uređaj



**NAPOMENA:** U FAN načinu rada, možete postaviti temperaturu. Kao rezultat, na zaslonu daljinskog upravljača se ne prikazuje temperatura

## Postavljanje TAJMERA

**TIMER ON/OFF** - Postavljanje vremena nakon kojega će se jedinica automatski uključiti / isključiti.

### TIMER ON postavka

Pritisnite TIMER tipku za pokretanje ON sekvence

Pritisnite Temp. tipke gore ili dolje za postavljanje vremenskog razdoblja nakon kojeg želite da se jedinica UKLJUČI. Pričekajte 1 sekundu za aktiviranje vremena za uključivanje jedinice

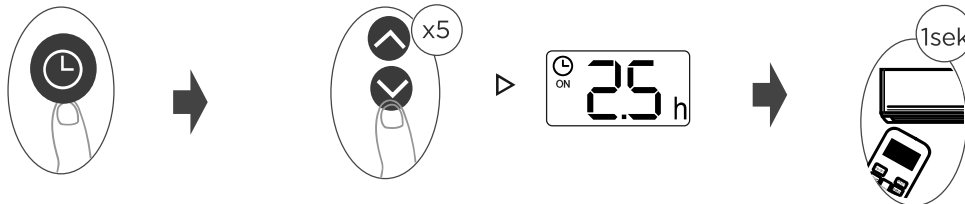

### TIMER OFF postavka

Pritisnite TIMER tipku za pokretanje OFF sekvence

Pritisnite Temp. tipke gore ili dolje za postavljanje vremenskog razdoblja nakon kojeg želite da se jedinica ISKLJUČI. Pričekajte 1 sekundu za aktiviranje vremena za isključivanje jedinice

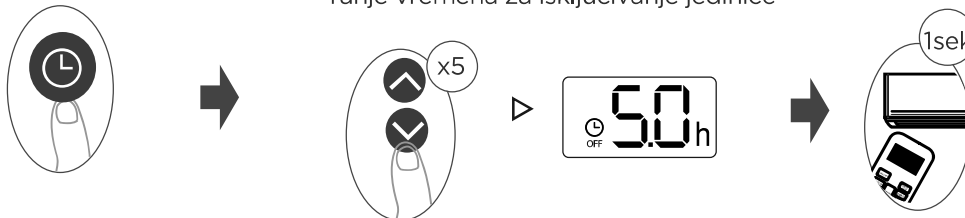

### NAPOMENA:

- Prilikom postavljanja TIMER ON ili TIMER OFF, vrijeme će se sa svakim pritiskom povećavati u koracima od 30 minuta, do 10 sati. Nakon 10 sati pa sve do 24, povećavat će se u koracima od 1 sata. (Na primjer, pritisnite tipku 5 puta kako biste dobili 2,5h i pritisnite 10 puta kako biste dobili 5h,) Mjerač vremena će se vratiti na 0,0 nakon 24
- Otkazite bilo koju funkciju postavljanjem mjerača vremena na 0.0h

### TIMER ON & OFF postavka (primjer)

Imajte na umu da se vremenska razdoblja koja postavite za obje funkcije odnose na sate nakon trenutnog vremena.

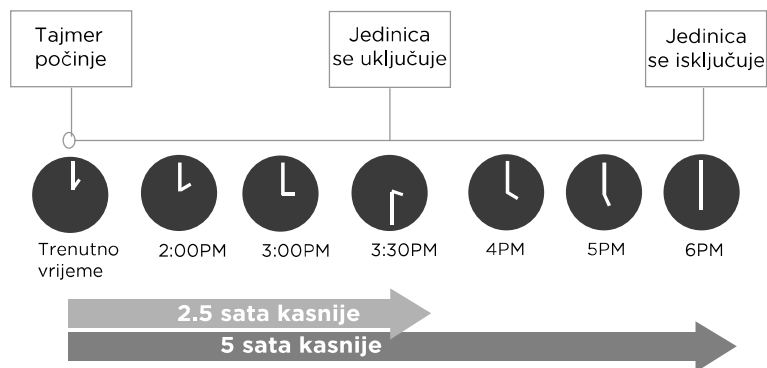
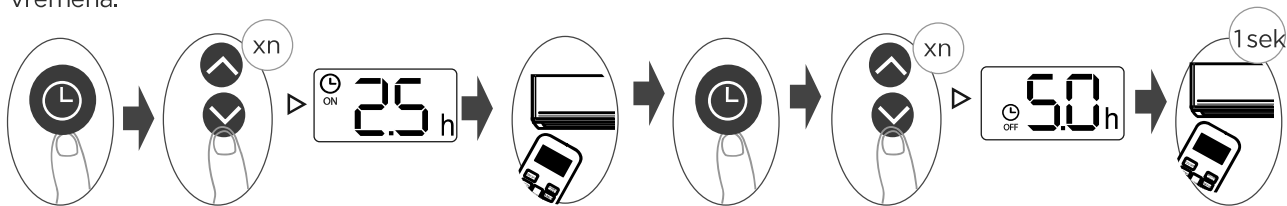

Primjer: ako je trenutni mjerac vremena 13:00, za postavljanje mjerača vremena prema gornjim koracima, jedinica će se uključiti 2,5 h kasnije (15:30) i isključiti u 18:00

## Kako koristiti napredne funkcije

### Swing funkcija

Pritisnite Swing tipku

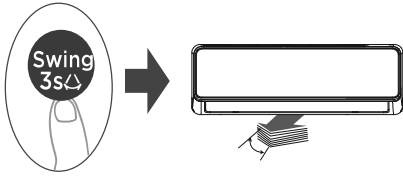

Vodoravna zaklopka će se automatski pomicati gore-dolje kada pritisnete tipku Swing

Postavite smjer strujanja zraka

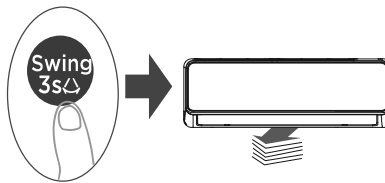

Ako više puta pritisnete tipku SWING, možete postaviti pet različitih smjerova strujanja zraka. Zaklopka će se postepeno pomicati svaki put kada pritisnete tipku. Pritišćite tipku dok ne dođete do željenog smjera.

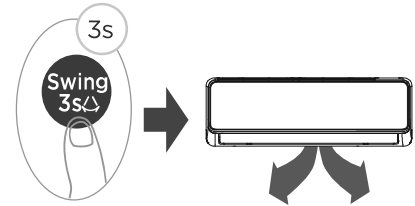

Držite tipku pritisnutu dulje od 3 sekunde kako biste aktivirali funkciju okomitog kretanja zaklopki. (ovisno o modelu)

Pritisnite Swing tipku

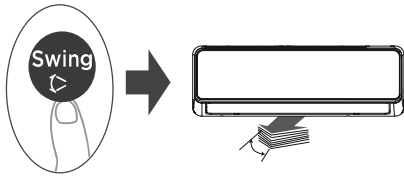

Vodoravna zaklopka će se automatski pomicati gore-dolje kada pritisnete tipku Swing

Postavite smjer strujanja zraka

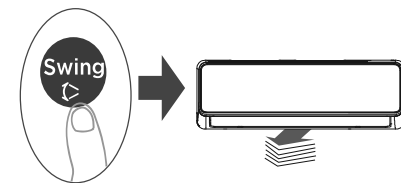

Ako više puta pritisnete tipku SWING, možete postaviti pet različitih smjerova strujanja zraka. Zaklopka će se postepeno pomicati svaki put kada pritisnete tipku. Pritišćite tipku dok ne dođete do željenog smjera.

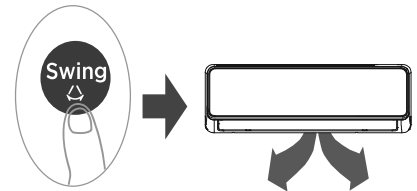

Pritisnite ovu tipku, aktivira se funkcija okomitog zakretanja zaklopki.

### LED ZASLON

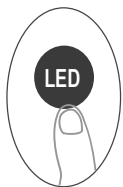

Pritisnite ovu tipku za uključivanje i isključivanje zaslona na unutarnjoj jedinici.

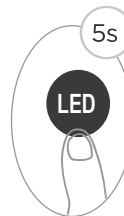

Pritisnite ovu tipku duže od 5 sekundi (neke jedinice)

Držite pritisnutu ovu tipku dulje od 5 sekundi i unutarnja jedinica će prikazati stvarnu sobnu temperaturu. Ponovnim pritiskom duže od 5 sekundi vratit ćete se na prikaz postavljene temperature.



### Cool/Heat Flash funkcija

Pritisnite ovu tipku

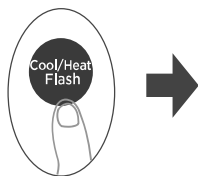

Kada pritisnete ovu tipku u COOL načinu rada, pokrenut će se funkcija Cool Flash. Jedinica će proizvesti veliku količinu zraka i visok protok zraka, temperatura cijele prostorije smanjit će se u kratkom vremenu

Kada pritisnete ovu tipku u HEAT načinu rada, pokrenut će se funkcija Heat Flash. Brzo i snažno strujanje vrućeg zraka zagrijat će cijelu vašu prostoriju u kratkom vremenu

### Cool/Heat Flash funkcija



Pritisnite ovu tipku za ulazak u jedan od sljedećih energetski učinkovitih načina rada  
ECO → GEAR(75%) → GEAR(50%) → Prethodni način rada → ECO.....

Napomena: Ova funkcija jedino je dostupna u COOL načinu rada.

### ECO funkcija:

Ako se koristi tijekom hlađenja, pritiskom na ovu tipku temperatura će se automatski postaviti na 24°C/75°F i postaviti brzinu ventilatora na automatski način rada radi uštede energije. Ako je postavljena temperatura viša, ostat će na toj postavci.

**NAPOMENA:** Ponovni pritisak na tipku ECO ili promjena načina rada ili podešavanje postavljene temperature na manje od 24°C/75°F zaustavit će ECO funkciju.

U ECO načinu rada, postavljena temperatura ne smije biti niža od 24°C/75°F. To može dovesti do nedovoljnog hlađenja. Ponovno pritisnite tipku ECO za povratak na normalan rad.

### GEAR funkcija:

Pritisnite tipku ECO/GEAR za ulazak u GEAR funkciju na sljedeći način:  
75%(do 75% potrošnje električne energije) → 50%(do 50% potrošnje električne energije) → Prethodni način rada.

U GEAR funkciji, zaslon na daljinskom upravljaču izmjenjivat će se između potrošnje električne energije i postavljene temperature.

### Silent funkcija

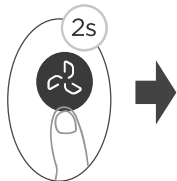

Držite pritisnutu tipku ventilatora dulje od 2 sekunde za aktiviranje/onemogućavanje Silent funkcije. Zbog niske frekvencije rada kompresora, može doći do nedovoljnog hlađenja ili grijanja. Pritiskom na tipku ON/OFF, Mode, Sleep, Boost ili Clean tijekom rada otkazat će se Silent funkcija.

### FP funkcija

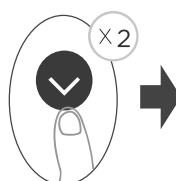

Dvaput brzo pritisnite ovaj tipku tijekom HEAT načina rada i postavljanje temperature na 16°C/60°F će aktivirati FP funkciju. Jedinica će raditi velikom brzinom ventilatora (dok je kompresor uključen) s temperaturom koja će se automatski postaviti na 8°C/46°F.

## SET funkcija

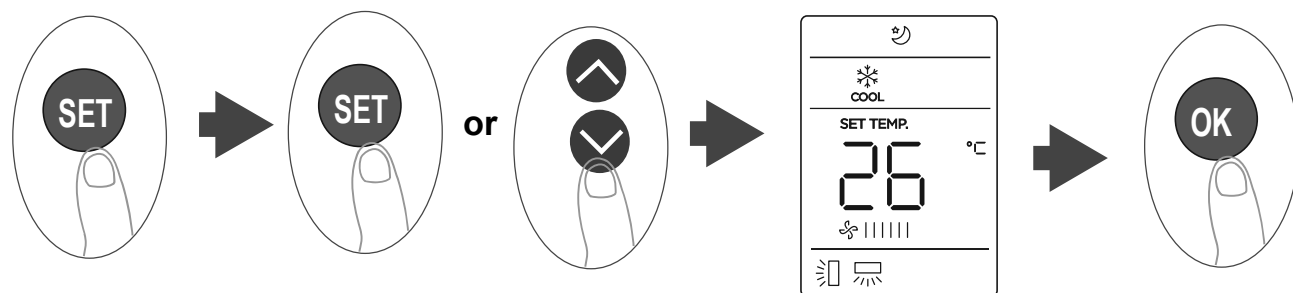

- Pritisnite tipku SET za promjenu funkcije, ponovno pritisnite tipku SET ili tipku TEMP $\downarrow$  ili TEMP $\uparrow$ , za odabir željene funkcije. Odabrani simbol će treptati na zaslonu, pritisnite tipku OK za potvrdu.
- Za poništavanje odabrane funkcije samo izvršite iste postupke kao gore.
- Pritisnite tipku SET za pomicanje kroz funkcije rada na sljedeći način: Active clean( $\text{☼}$ ) Sleep( $\text{☾}$ ) Follow Me( $\text{⊕}$ ) AP funkcija\* ( $\text{📶}$ )

### Active Clean funkcija

Tehnologija Active Clean uklanja prašinu i plijesan koji mogu uzrokovati neugodne mirise. Active Clean brzo zamrzava i odmrzava izmjenjivač topline kako bi očistio materijal koji se zalijepio za njega. Kada je ova funkcija uključena, unutarjna jedinica prikazuje "CL". Nakon 20 do 130 minuta, jedinica će se automatski isključiti i prekinuti funkciju CLEAN.

### Sleep funkcija( $\text{☾}$ ):

Funkcija SLEEP koristi se za smanjenje potrošnje energije dok spavate (i ne trebaju vam iste postavke temperature da vam bude ugodno).

**NAPOMENA:** SLEEP funkcija nije dostupna u FAN I DRY načinu rada

### AP funkcija ( $\text{📶}$ )(neke jedinice):

Upotrijebite tipku SET za odabir AP načina rada (pristupne točke) kako biste omogućili bežičnu konfiguraciju. Ako ova funkcija nije dostupna na ovom uređaju, možda ćete moći ući u AP način rada pritiskom na LED tipku 7 puta u 10 sekundi.

### Follow Me funkcija ( $\text{⊕}$ ):

Funkcija FOLLOW ME omogućuje daljinskom upravljaču mjerenje temperature na trenutnoj lokaciji i slanje tog signala klima uređaju u intervalima od 3 minute.

Kada koristite načine rada AUTO, COOL ili HEAT, mjerenje temperature okoline s daljinskog upravljača (umjesto sa same unutarjne jedinice) omogućit će klima uređaju da optimizira temperaturu oko vas i osigura maksimalnu udobnost.

**NAPOMENA:** Pritisnite i držite tipku Cool/Heat Flash 7 sekundi za pokretanje/zaustavljanje memorijske značajke Follow Me funkcije.

- Ako je memorijska značajka aktivirana, na zaslonu se na 3 sekunde prikazuje "On".
- Ako je memorijska značajka zaustavljena, na zaslonu se na 3 sekunde prikazuje "OF".
- Dok je memorijska značajka aktivirana, pritiskom na tipku ON/OFF, promjenom načina rada ili nestankom struje neće se otkazati funkcija Follow Me

## Podešavanje i uporaba aplikacije

### Značajka bežične kontrole

#### Primjenjivi sustav: iOS, Android

- Neka vaša aplikacija bude ažurna s najnovijom verzijom.
- Nisu svi Android i iOS sustavi kompatibilni s aplikacijom. Izričito izjavljujemo da se nećemo smatrati odgovornima za bilo koji problem koji bi nastao zbog nekompatibilnosti

#### Strategija bežične sigurnosti

- Smart Kit samo podržava WPA-PSK/WPA2-PSK enkripciju i bez enkripcije. Preporučena je WPA-PSK/WPA2-PSK enkripcija.

#### MJERE OPREZA:

- Problemi s mrežom mogu povremeno uzrokovati isteke vremena. Zaslone jedinice i aplikacija mogu postati nesinkronizirani, ali to će se riješiti samo od sebe kada se mrežna veza ponovno uspostavi.
- Kamere pametnih telefona moraju imati 5 megapiksela ili više za ispravno skeniranje QR koda.
- Ako mreža ostane nedostupna, možda će biti potrebno ponovno pokrenuti proces konfiguracije. Aplikacija je podložna ažuriranjima bez prethodne najave radi poboljšanja funkcija proizvoda.
- Stvarni postupak mrežne konfiguracije može se malo razlikovati od priručnika.
- Više informacija potražite na web stranici usluge

#### SPECIFIKACIJE:

- Model APP kontrolnog modula: EU-SK110, US-SK110
- Tip antene: Elektronska PCB antena
- Frekvencijsko područje: 2400-2483.5MHz
- Radna temperatura: 0°C~45°C/32°F~113°F
- Vlažnost: 10%~85%
- Napajanje: DC 5V/500mA
- Maksimalna TX snaga: <20dBm

#### PRIPREMA

- Provjerite je li vaš mobilni uređaj povezan s bežičnim usmjerivačem. Bežični usmjerivač već bi trebao biti spojen na Internet prije registracije korisnika i konfiguracije mreže.
- Radije uklonite nepotrebne bežične mreže na svom telefonu kako biste izbjegli probleme tijekom procesa konfiguracije

#### Preuzimanje i instalacija aplikacije

1. Provjerite je li vaš mobilni telefon povezan s kućnom mrežom.
2. Skenirajte QR kod svojim uređajem ili potražite aplikaciju MSmartHome u trgovini Google Play ili Apple App Store



## Konfiguracija mreže

### OPREZ:

- Kao što je gore spomenuto, uklonite ili “zaboravite” druge nepotrebne Wi-Fi mreže, osobito ako su u blizini. Vaš bi uređaj trebao biti spojen na istu mrežu na koju ćete spojiti jedinicu.
- Budući da će se vaš telefon privremeno povezati s klima uređajem, vaš telefon mora biti postavljen da se automatski ponovno poveže s vašom bežičnom mrežom kada proces završi

### Prijateljski podsjetnik:

- Svi koraci za konfiguraciju mreže moraju biti dovršeni u roku od 8 minuta nakon uključivanja klima uređaja, inače ćete ga morati isključiti i ponovo uključiti..

### NAPOMENA:

- Provjerite jesu li vaši uređaji uključeni.
- Držite svoj mobilni telefon dovoljno blizu jedinice kada konfigurirate mrežu za jedinicu.
- Povežite vaš mobilni telefon s kućnom bežičnom mrežom i provjerite znate li lozinku mreže.
- Provjerite podržava li vaš usmjerivač bežični pojas od 2,4 GHz i je li uključen. Ako niste sigurni podržava li usmjerivač pojas od 2,4 GHz, obratite se proizvođaču usmjerivača.
- Uređaj se ne može povezati s bežičnom mrežom koja zahtijeva autentifikaciju. Obično bežična mreža u javnim prostorima kao što su hoteli, restorani itd. radi na ovaj način. Povežite se na bežičnu mrežu koja ne zahtijeva provjeru autentičnosti.
- Preporuča se koristiti naziv bežične mreže koji sadrži samo slova i brojke, a ne posebne znakove.
- Ako naziv vaše bežične mreže sadrži posebne znakove, promijenite ga na usmjerničku. Vaš telefon i drugi uređaji tada će morati biti ponovno konfigurirani na vašu bežičnu vezu.
- Isključite funkciju WLAN+ (Android) ili WLAN Assistant (iOS) na svom mobilnom telefonu kada konfigurirate jedinicu.
- U slučaju da se vaš uređaj prije povezivao s bežičnom mrežom, ali se mora ponovno povezati, kliknite “+” na početnoj stranici aplikacije i ponovno dodajte svoj uređaj prema kategoriji uređaja i modelu prema uputama na aplikaciji.

### Registrirajte se i prijavite se

Otvorite aplikaciju MSmart home. Ako imate postojeći račun, koristite ovo za prijavu ili stvaranje novog računa. Također je moguće za prijavu koristiti platformu treće strane, ali s ograničenim značajkama



## Povežite vaše uređaje na MSmartHome

1. Provjerite je li vaš mobilni telefon povezan s bežičnom mrežom i je li Bluetooth uključen. Ako to nije slučaj, uđite u postavke telefona i uključite ih.
2. Uključite uređaje s kojima se želite povezati.
3. Otvorite aplikaciju MSmartHome na svom telefonu.
4. Ako se pojavi poruka “Pametni uređaji otkriveni u blizini”, kliknite na ovo za dodavanje automatski otkrivenih uređaja



5. Ako se poruka ne prikaže, odaberite “+” i odaberite svoj uređaj s popisa dostupnih uređaja u blizini. Ako vaš uređaj nije naveden, dodajte ga ručno odabirom kategorije uređaja [Air Conditioner] i modela uređaja [Split AC]

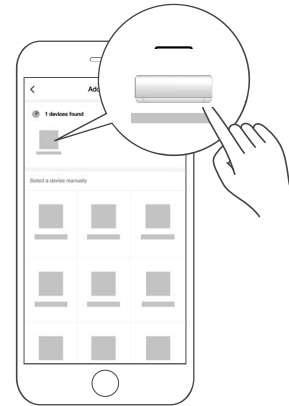

6. Povežite uređaj s aplikacijom slijedeći upute. Ako veza ne uspije, slijedite upute aplikacije kako biste nastavili s postupkom.

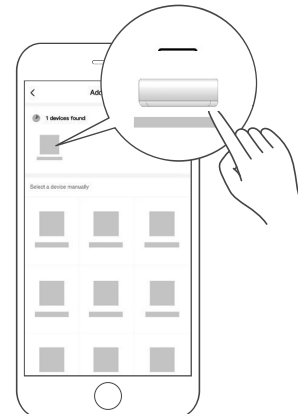

## Kako koristiti aplikaciju

Provjerite jesu li i vaš mobilni uređaj i klima uređaj povezani s internetom prije upotrebe aplikacije za upravljanje klima uređajem. Kada budete spremni, slijedite ove korake:



1. Kliknite "Login"

2. Odaberite klima uređaj

### NAPOMENA:

Nisu sve funkcije aplikacije dostupne za sve klima uređaje. Na primjer: ECO, Boost, Swing funkcija. Više informacija potražite u korisničkom



3. Pomoću aplikacije sada je moguće kontrolirati uključenost/isključenost klima uređaja, način rada, temperaturu, brzinu ventilatora i tako dalje

## Specijalne funkcije

Raspored, krivulja spavanja, monitor energije, kontrola računa i provjera

### NAPOMENA:

Neke posebne funkcije u aplikaciji možda neće biti primjenjive na sve jedinice. Ako klima uređaj ne podržava funkciju.

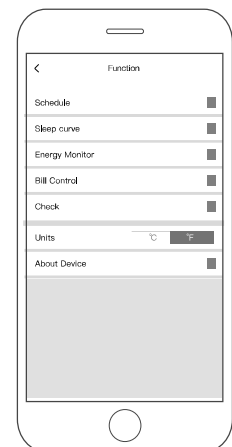

### Raspored (Schedule)

Korisnici mogu uključiti ili isključiti svoj klima uređaj u određeno vrijeme. Raspored se može dodatno automatizirati odabirom dana za ponavljanje rasporeda.

### Spavanje (Sleep)

Funkcija spavanja štedi energiju slabijim hlađenjem ili grijanjem te pomaže spavanju prateći tipične promjene temperature tijela tijekom spavanja

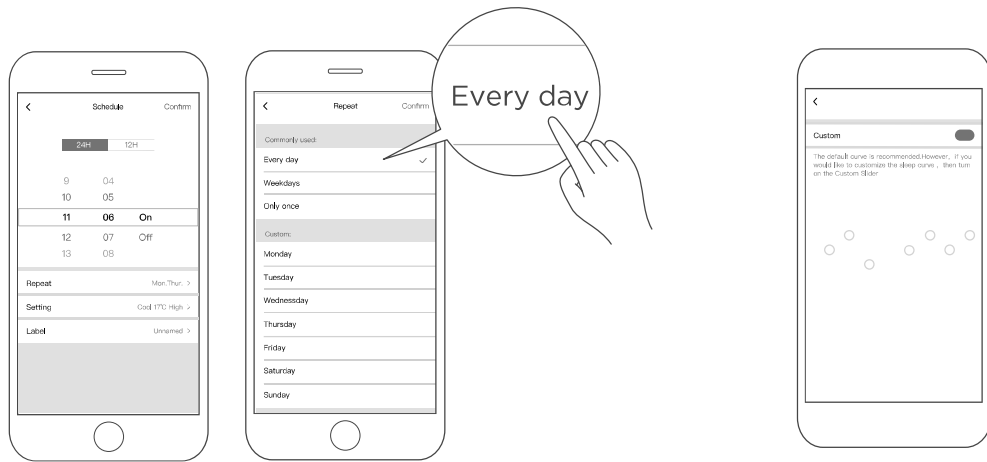

### Nadzor energije (Energy Monitor) (samo za neke jedinice)

Korisnici mogu jednostavno pratiti potrošnju električne energije svog klima uređaja provjeravajući grafikon i povijesne zapise

### Kontrola računa (Bill Control) (ne sve jedinice)

Korisnik može postaviti parametre za ograničavanje potrošnje električne energije tijekom određenog vremenskog razdoblja

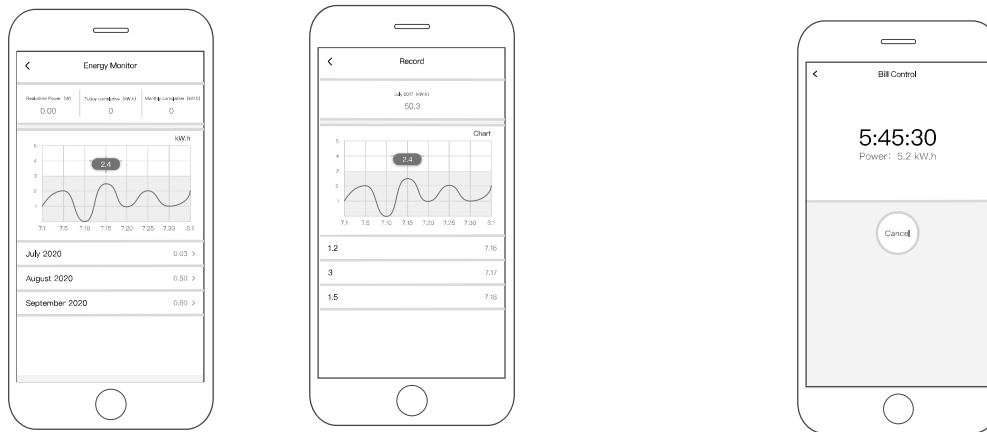

### Provjera (Check)

Korisnik također može pomoću ove funkcije provjeriti radni status klima uređaja. Uobičajeni događaji, iznimni događaji i detaljne informacije o razini mogu se pogledati ovdje.

## IZJAVA O SUKLADNOSTI

Ovime izjavljujemo da je ovaj Smart kit u skladu s osnovnim zahtjevima i drugim relevantnim odredbama Direktive 2014/53/EU. Kopija pune DoC je priložena. (Samo proizvodi iz Europske unije)

### OPREZ:

**Modeli bežičnog modula:** US-SK110,EU-SK110:

**FCC ID:** 2ADQOMDNA23

**IC:** 12575A-MDNA23

Ovaj uređaj u skladu je s dijelom 15 FCC pravila i sadrži odašiljače/prijemnike izuzete od licence koji su u skladu s RSS-ovima koji su izuzeti od licence Innovation, Science and Economic Development Canada.

### Rad je podložen sljedećim uvjetima:

1. Ovaj uređaj ne smije uzrokovati smetnje; i
2. Ovaj uređaj mora prihvatiti sve smetnje, uključujući smetnje koje mogu uzrokovati neželjeni rad uređaja.

Upravlajte uređajem samo u skladu s priloženim uputama. Promjene ili preinake na ovoj jedinici koje nije izričito odobrila strana odgovorna za sukladnost mogu poništiti korisnikovo ovlaštenje za rukovanje opremom. Ovaj uređaj sukladan je FCC ograničenjima izloženosti zračenju utvrđena za nekontrolirano okruženje. Kako bi se izbjegla mogućnost prekoračenja FCC ograničenja izloženosti radiofrekvencijama, tijekom normalnog rada razmak između ljudi i antene ne smije biti manji od 20 cm (8 inča).

**NAPOMENA:** Ova je oprema testirana i utvrđeno je da je u skladu s ograničenjima za digitalne uređaje klase B, u skladu s dijelom 15 FCC pravila. Ova su ograničenja osmišljena kako bi pružila razumnu zaštitu od štetnih smetnji u stambenim instalacijama. Ova oprema generira, koristi i može zračiti radiofrekventnu energiju i, ako se ne instalira i koristi u skladu s uputama, može uzrokovati štetne smetnje radijskim komunikacijama. Međutim, nema jamstva da se smetnje neće pojaviti u određenoj instalaciji. Ako ova oprema uzrokuje štetne smetnje radijskom ili televizijskom prijemniku, što se može utvrditi uključivanjem i isključivanjem opreme, korisnik se potiče da pokuša ispraviti smetnje jednom ili više sljedećih mjera:

- Preusmjerite ili premjestite prijemnu antenu.
- Povećajte razmak između opreme i prijemnika.
- Spojite opremu u utičnicu na strujnom krugu različitom od onog na koji je spojen prijemnik.
- Za pomoć se obratite prodavaču ili iskusnom radio/TV tehničaru



# BRIGA I ODRŽAVANJE

## ⚠ OPREZ

- Začepljen klima uređaj može smanjiti učinkovitost vaše jedinice ili možda utjecati na vaše zdravlje. Očistite filtar svaka dva tjedna.
- Uvijek ISKLJUČITE svoj AC sustav i odspojite njegovo napajanje prije čišćenja ili održavanja.
- Ne dirajte filtar za osvježavanje zraka (plazma) najmanje 10 minuta nakon isključivanja jedinice.
- Koristite samo meku, suhu krpu za brisanje jedinice. Možete upotrijebiti krpu namočenu u toplu vodu za brisanje jedinice ako je jedinica posebno prljava.
- Za čišćenje jedinice nemojte koristiti kemikalije ili kemijski tretirane krpe
- Ne koristite benzen, razrjeđivač, prašak za poliranje ili druga otapala za čišćenje jedinice. Oni mogu uzrokovati pucanje ili deformaciju plastične površine.
- Za čišćenje prednje ploče, nemojte koristiti vodu topliju od 40°C (104°F). To može uzrokovati deformaciju ploče ili promjenu boje

## Čišćenje vaše unutarnje jedinice, filtra zraka

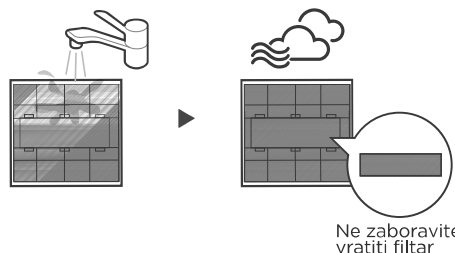
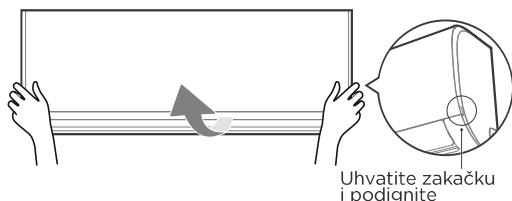

### Korak 1:

Podignite prednju ploču unutarnje jedinice.

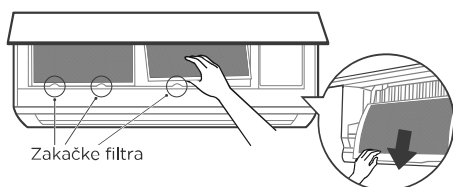

### Korak 2:

Uхватite zakačku na kraju filtra, podignite ga, zatim povucite prema sebi i izvucite filtar.

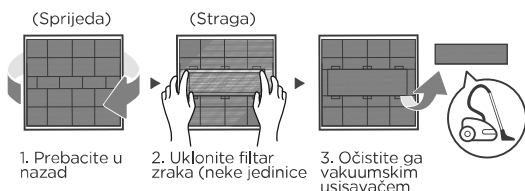

### Korak 3:

Ako vaš filtar ima mali filtar za osvježavanje zraka, odvojite ga od većeg filtra. Očistite ovaj filtar za osvježavanje zraka ručnim usisavačem.

### Korak 4:

Očistite veliki filtar za zrak toplom vodom sa sapunom. Svakako koristite blagi deterdžent. Isperite filtar svježom vodom, zatim otresite višak vode. Osušite ga na hladnom i suhom mjestu i suzdržite se od izlaganja direktnoj sunčevoj svjetlosti.



### Korak 5:

Kad se osuši, ponovno pričvrstite filtar za osvježavanje zraka na veći filtar, a zatim ga gurnite natrag u unutarnju jedinicu. Na kraju zatvorite prednju ploču unutarnje jedinice.

## ⚠ ВНИМАНИЕ

- Prije mijenjanja filtera ili čišćenja, isključite jedinicu i odspojite napajanje.
- Prilikom uklanjanja filtera ne dirajte metalne dijelove u jedinici. Oštri metalni rubovi mogu vas posjeći.
- Nemojte koristiti vodu za čišćenje unutrašnjosti unutarnje jedinice. To može uništiti izolaciju i uzrokovati
- Električni udar.
- Nemojte tijekom sušenja izlagati filter direktnoj sunčevoj svjetlosti. To može smanjiti.

### Podsjetnici filtra zraka (opcija)

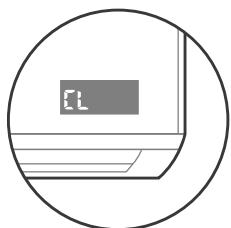

Prikaz na zaslonu: "CL"

#### Podsjetnik za čišćenje filtra zraka

- Nakon 240 sati korištenja, na prozoru zaslona na unutarnjoj jedinici treptat će "CL." Ovo je podsjetnik da očistite filter. Nakon 15 sekundi, jedinica će se vratiti na prethodni prikaz.
- Za poništavanje podsjetnika pritisnite LED tipku na daljinskom upravljaču 4 puta ili pritisnite 3 puta tipku **MANUAL CONTROL**. Ako ne poništite podsjetnik, indikator "CL" ponovno će treptati kada ponovno pokrenete jedinicu

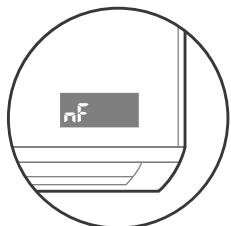

Prikaz na zaslonu: "nF"

#### Podsjetnik za zamjenu filtra zraka

- Nakon 2880 sati korištenja, na prozoru zaslona na unutarnjoj jedinici treptat će "nF." Ovo je podsjetnik da zamijenite filter. Nakon 15 sekundi, jedinica će se vratiti na prethodni prikaz.
- Za poništavanje podsjetnika pritisnite LED tipku na daljinskom upravljaču 4 puta ili pritisnite 3 puta tipku **MANUAL CONTROL**. Ako ne poništite podsjetnik, indikator "nF" ponovno će treptati kada ponovno pokrenete jedinicu

### Održavanje vašeg klima uređaja

#### Održavanje–Dulje razdoblje neuporabe

Ako ne planirate koristiti klima uređaj dulje vrijeme, učinite sljedeće:



Očistite filtre zraka



Uključite FAN funkciju dok se ne osuši do kraja



Isključite jedinicu i odspojite napajanje

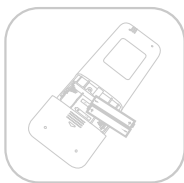

Izvadite baterije iz daljinskog upravljača

#### Održavanje–Inspekcija prije sezone

Nakon dugih razdoblja neuporabe ili prije razdoblja česte uporabe učinite sljedeće:



Provjerite oštećene žice

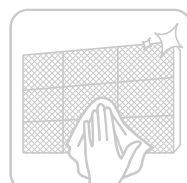

Očistite sve filtre



Provjerite curenja



Provjerite da ništa ne blokira sve ulaze i izlaze zraka

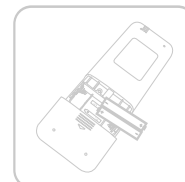

Zamijenite baterije

# RJEŠAVANJE PROBLEMA

## ⚠ OPREZ

Ako se dogodi bilo koji od sljedećih uvjeta, odmah isključite uređaj!

- Kabel za napajanje je oštećen ili nenormalno topao
- Osjećate miris paljevine
- Jedinica emitira glasne ili nenormalne zvukove
- Pregori osigurač ili se prekidač strujnog kruga često aktivira
- Jedinica dolazi u dodir s vodom ili ispušta vodu.

**NEMOJTE POKUŠAVATI SAMI RIJEŠITI OVE PROBLEME! ODMAH KONTAKTIRAJTE OVLAŠTENI SERVIS.**

## Uobičajeni problemi

Sljedeći problemi ne predstavljaju kvar i u većini slučajeva neće zahtijevati popravak.

Problem	Mogući uzroci
Jedinica se ne pali pritiskom tipke ON/OFF	Jedinica ima 3-minutnu zaštitu koja sprječava preopterećenje jedinice. Jedinica se ne može ponovno pokrenuti unutar tri minute nakon isključivanja.
Jedinica se mijenja iz načina COOL/HEAT u način FAN	Jedinica može promijeniti svoju postavku kako bi spriječila stvaranje leda na jedinici. Nakon što se temperatura poveća, jedinica će ponovno početi raditi u prethodno odabranom načinu rada. Nakon što je zadana temperatura postignuta, jedinica će automatski isključiti kompresor. Jedinica će nastaviti s radom kada se temperatura ponovno promijeni
Unutarnja jedinica emitira bijelu maglicu	U vlažnim područjima, velika temperaturna razlika između zraka u prostoriji i klimatiziranog zraka može uzrokovati bijelu maglicu
I unutarnja i vanjska jedinica emitiraju bijelu maglicu	Kada se jedinica ponovno pokrene u HEAT načinu rada nakon odmrzavanja, može se emitirati bijela maglica zbog vlage koja nastaje tijekom procesa odmrzavanja
Unutarnja jedinica proizvodi povremene zvukove	Zvuk strujanja zraka može se pojaviti kada se zaklopka ponovno postavi u svoj položaj. Nakon rada jedinice u HEAT načinu rada može se čuti škripavi zvuk zbog širenja i skupljanja plastičnih dijelova jedinice
I unutarnja i vanjska jedinica proizvode buku	Jedinica emitira tihi šištav zvuk tijekom rada: To je normalno i uzrokovano je rashladnim plinom koji teče kroz unutarnju i vanjsku jedinicu Jedinica emitira tihi šištav zvuk kada se sustav pokrene, kada je upravo prestao raditi ili se odmrzava: Ova buka je normalna i uzrokovana je zaustavljanjem rashladnog plina ili promjenom smjera Jedinica emitira škripavi zvuk: normalno širenje i skupljanje plastičnih i metalnih dijelova uzrokovano temperaturnim promjenama tijekom rada može uzrokovati škripanje

Problem	Mogući uzroci
Vanjska jedinica proizvodi zvukove	Jedinica će proizvoditi različite zvukove ovisno o trenutnom načinu rada
Prašina se emitira iz unutarnje ili vanjske jedinice	Jedinica može nakupiti prašinu tijekom duljih razdoblja neuporabe, koja će se ispuštati kada se jedinica uključi. To se može ublažiti pokrivanjem jedinice tijekom dugih razdoblja neaktivnosti
Jedinica emitira neugodan miris	Jedinica može apsorbirati mirise iz okoline (poput namještaja, kuhanja, cigareta, itd.) koji će se emitirati tijekom rada Filteri jedinice su postali pljesnivi i treba ih očistiti
Ventilator vanjske jedinice ne radi	Tijekom rada, brzina ventilatora se kontrolira kako bi se optimizirao rad proizvoda
Rad je nepravilan, nepredvidiv ili jedinica ne reagira	Smetnje od tornjeva mobilne telefonije i repetitora mogu uzrokovati kvar jedinice U tom slučaju pokušajte sljedeće: <ul style="list-style-type: none"> <li>• Odspojite napajanje, zatim ga ponovno spojite.</li> <li>• Pritisnite tipku ON/OFF na daljinskom upravljaču za ponovno pokretanje rada.</li> </ul>

**NAPOMENA:** Ako se problem nastavi, obratite se lokalnom prodavaču ili najbližem centru za korisničku podršku. Dajte im detaljan opis kvara jedinice kao i svoj broj modela.

**⚠ OPREZ**

Ako se pojave problemi, provjerite sljedeće točke prije nego kontaktirate servis.

Problem	Mogući uzroci	Rješenje
Slabe performanse hlađenja	Postavka temperature može biti viša od sobne temperature	Smanjite postavku temperature
	Izmjenjivač topline na unutarnjoj ili vanjskoj jedinici je prljav	Očistite oštećeni izmjenjivač topline
	Filtar zraka je zaprljan	Uklonite filtari i očistite ga prema uputama
	Ulaz ili izlaz zraka bilo koje jedinice je blokiran	Isključite jedinicu, uklonite prepreku i ponovno je uključite
	Vrata i prozori su otvoreni	Uvjerite se da su tijekom rada jedinice sva vrata i prozori zatvoreni
	Prekomjernu toplinu stvara sunčeva svjetlost	Zatvorite prozore i zavjese tijekom razdoblja velikih vrućina ili jakog sunca
	Previše izvora topline u prostoriji (ljudi, računala, elektronika, itd.)	Smanjite količinu izvora topline
	Aktivirana je SILENT funkcija (opcijska funkcija)	SILENT funkcija može smanjiti performanse uređaja smanjivanjem učestalosti rada. Isključite SILENT funkciju

Problem	Mogući uzroci	Rješenje
Jedinica ne radi	Prekid napajanja	Pričekajte vraćanje napajanja
	Napajanje je isključeno	Uključite napajanje
	Pregorio osigurač	Zamijenite osigurač
	Prazne baterije daljinskog upravljača	Zamijenite baterije
	Aktivirana je 3-minutna zaštita jedinice	Pričekajte tri minute nakon ponovnog pokretanja jedinice
	Tajmer je aktiviran	Isključite tajmer
Jedinica se često pokreće i zaustavlja	U sustavu ima previše ili premalo rashladnog sredstva	Kontaktirajte ovlaštenu servisnu službu
	Nekompresibilni plin ili vlaga ušli su u sustav	
	Kompresor je u kvaru	
	Napon je previsok ili prenizak	
Slabe performanse grijanja	Vanjska temperatura je preniska	Koristite pomoćni uređaj za grijanje
	Hladan zrak ulazi kroz vrata i prozore	Uvjerite se da su sva vrata i prozori tijekom uporabe zatvoreni
	Niska količina rashladnog sredstva zbog curenja ili dugotrajne uporabe	Kontaktirajte ovlaštenu servisnu službu
Lampice indikatora nastavljaju treptati	Jedinica može prestati s radom ili nastaviti sigurno raditi. Ako indikatorske lampice nastavite treptati ili se pojave kodovi grešaka, pričekajte oko 10 minuta. Problem se može riješiti sam od sebe. Ako nije, isključite napajanje, a zatim ga ponovno uključite. Uključite jedinicu. Ako se problem nastavi, isključite napajanje i obratite se najbližem centru za korisničku podršku	
Za bilo koji od sljedećih kodova pogreške, učinite kako je ovdje navedeno: <ul style="list-style-type: none"> <li>• E(x), P(x), F(x)</li> <li>• EH(xx), EL(xx), EC(xx)</li> <li>• PH(xx), PL(xx), PC(xx)</li> </ul>		

**NAPOMENA:** Ako se vaš problem nastavi pojavljivati nakon obavljanja gore navedenih provjera i dijagnostike, odmah isključite jedinicu i kontaktirajte ovlaštenu servisnu službu.

# TRŽIŠNI ZNAKOVI, PRAVA KOPIRANJA I PRAVNE NAPOMENE

Midea logotip, riječne oznake, trgovački naziv, trgovački izgled i sve njihove verzije vrijedna su imovina Midea Grupe i/ili njenih podružnica ("Midea"), na koje Midea posjeduje trgovačke znakove, autorska prava i druga prava intelektualnog vlasništva, te sav goodwill proizašli iz korištenja bilo kojeg dijela Midea zaštitnog znaka. Korištenje zaštitnog znaka Midea u komercijalne svrhe bez prethodnog pisanog pristanka Midee može predstavljati povredu zaštitnog znaka ili nelojalnu konkurenciju kojom se krše relevantni zakoni.

Ovaj priručnik izradila je Midea i Midea zadržava sva autorska prava. Niti jedan subjekt ili pojedinac ne smije koristiti, umnožavati, mijenjati, distribuirati u cijelosti ili djelomično ovaj priručnik, ili pakirati ili prodavati s drugim proizvodima bez prethodnog pisanog pristanka Midee

## ZBRINJAVANJE I RECIKLIRANJE

### Važne upute za okoliš (Europske smjernice za zbrinjavanje)

Usklađenost s WEEE Direktivom i zbrinjavanje otpadnog proizvoda:  
Ovaj je proizvod u skladu s EU WEEE Direktivom (2012/19/EU). Ovaj proizvod nosi klasifikacijski simbol za otpadnu električnu i elektroničku opremu (WEEE).

Ovaj simbol označava da se ovaj proizvod ne smije odlagati zajedno s drugim kućnim otpadom na kraju njegovog životnog vijeka. Iskorišteni uređaj mora se vratiti na službeno sabirno mjesto za recikliranje električnih i elektroničkih uređaja. Kako biste pronašli ove lokacije prikupljanja, obratite se lokalnim vlastima ili prodavaču kod kojeg je proizvod kupljen.

Svako kućanstvo ima važnu ulogu u uporabi i recikliranju starih uređaja. Odgovarajuće zbrinjavanje rabljenog uređaja pomaže u sprječavanju mogućih negativnih posljedica za okoliš i ljudsko zdravlje



# NAPOMENA O ZAŠTITI PODATAKA

Za pružanje usluga dogovorenih s kupcem, suglasni smo da ćemo se bez ograničenja pridržavati svih odredbi važećeg zakona o zaštiti podataka, u skladu sa zemljama u sklopu ovog dogovora unutar kojih će se pružati usluge klijentu, kao i, gdje je primjenjivo, Opće uredbe o zaštiti podataka EU (GDPR).

Općenito, naša obrada podataka služi za ispunjavanje naše obveze prema ugovoru s vama i iz sigurnosnih razloga proizvoda, kako bismo zaštitili vaša prava u vezi s pitanjima o jamstvu i registraciji proizvoda. U nekim slučajevima, ali samo ako je osigurana odgovarajuća zaštita podataka, osobni podaci mogu se prenijeti primateljima koji se nalaze izvan Europskog gospodarskog prostora.

Dodatne informacije možete dobiti na zahtjev. Našeg službenika za zaštitu podataka možete kontaktirati putem [MideaDPO@midea.com](mailto:MideaDPO@midea.com). Kako biste ostvarili svoja prava kao što je pravo na prigovor na obradu vaših osobnih podataka u svrhe izravnog marketinga, kontaktirajte nas putem [MideaDPO@midea.com](mailto:MideaDPO@midea.com). Kako biste prošli dodatne informacije, molimo slijedite QR kod

Radi poboljšanja proizvoda, dizajn i specifikacije podložni su promjenama bez prethodne najave. Za detalje se obratite distributeru ili proizvođaču. Sva ažuriranja priručnika bit će prenesena na web stranicu servisa, provjerite najnoviju verziju

Uvoznik: Frigo-kor d.o.o Majstorska 11 10000 Zagreb Croatia

Proizvođač: GD Midea Air-Conditioning Equipment Co.,Ltd.  
Lingang Road Beijiao Shunde Foshan Guangdong  
Narodna Republika Kina 528311



[www.midea.com](http://www.midea.com)  
© Midea 2022 all rights reserved

CS021UI-CB(OBM)  
16122000A73580



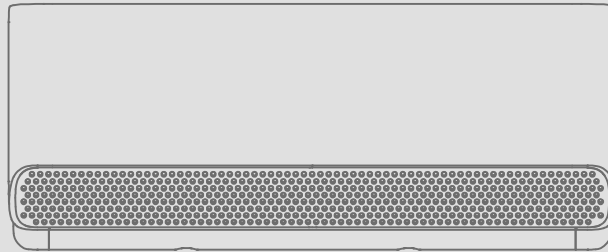

**Room Air Conditioner**



**MSmartHome**  
Download the app  
& activate product

# **USER MANUAL**

**MODEL NUMBER:**  
**CB1-09HRFN8-I**  
**CB1-12HRFN8-I**

Warning notices: Before using this product, please read this manual carefully and keep it for future reference. The design and specifications are subject to change without prior notice for product improvement. Consult with your dealer or manufacturer for details. The diagram above is just for reference. Please take the appearance of the actual product as the standard.

## THANK YOU LETTER

Thank you for choosing Midea! Before using your new Midea product, please read this manual thoroughly to ensure that you know how to operate the features and functions that your new appliance offers in a safe way.

## CONTENTS

THANK YOU LETTER .....	01
SAFETY PRECAUTIONS .....	02
SPECIFICATIONS .....	06
PRODUCT OVERVIEW .....	07
PRODUCT INSTALLATION .....	08
Install Your Indoor Unit .....	10
Install Your Outdoor Unit .....	19
Refrigerant Piping Connection .....	23
Air Evacuation .....	27
Electrical And Gas Leak Checks .....	29
Test Run .....	30
Packing And Unpacking The Unit .....	31
OPERATION INSTRUCTIONS .....	32
Indoor Unit Display .....	32
Remote Control Operation .....	37
App Setup And Operation .....	48
CARE AND MAINTENANCE .....	54
TROUBLESHOOTING .....	56
TRADEMARKS, COPYRIGHTS AND LEGAL STATEMENT .....	59
DISPOSAL AND RECYCLING .....	59
DATA PROTECTION NOTICE .....	60

# SAFETY PRECAUTIONS

It's really important you read Safety Precautions Before Operation and Installation. Incorrect installation due to ignoring instructions can cause serious damage or injury. The seriousness of potential damage or injuries is classified as either a **WARNING** or **CAUTION**.

## Explanation of Symbols



### **Warning of electrical voltage**

This symbol indicates that there is a danger to life and health of persons due to voltage.



### **Warning**

The signal word indicates a hazard with a medium level of risk which, if not avoided, may result in death or serious injury.



### **Caution**

The signal word indicates a hazard with a low degree of risk which, if not avoided, may result in minor or moderate injury.



### **Attention**

The signal word indicates important information (e.g. damage to property), but not danger.



### **Observe instructions**

This symbol indicates that a service technician should only operate and maintain this appliance in accordance with the operating instructions.

Read these operating instructions carefully and attentively before using/commissioning the unit and keep them in the immediate vicinity of the installation site or unit for later use!

## **WARNING**

This appliance can be used by children aged from 8 years and above and persons with reduced physical, sensory or mental capabilities or lack of experience and knowledge if they have been given supervision or instruction concerning use of the appliance in a safe way and understand the hazards involved. Children shall not play with the appliance. Cleaning and user maintenance shall not be made by children without supervision(European Union countries).

This appliance is not intended for use by persons(including children) with reduced physical, sensory or mental capabilities, or lack of experience and knowledge, unless they have been given supervision or instruction concerning use of the appliance by a person responsible for their safety. Children should be supervised to ensure that they do not play with the appliance.

## **⚠ WARNING FOR PRODUCT USE**

- If an abnormal situation arises (like a burning smell), immediately turn off the unit and disconnect the power. Call your dealer for instructions to avoid electric shock, fire or injury.
- Do not insert fingers, rods or other objects into the air inlet or outlet. This may cause injury, since the fan may be rotating at high speeds.
- Do not use flammable sprays such as hair spray, lacquer or paint near the unit. This may cause fire or combustion.
- Do not operate the air conditioner in places near or around combustible gases. Emitted gas may collect around the unit and cause explosion.
- Do not operate your air conditioner in a wet room such as a bathroom or laundry room. Too much exposure to water can cause electrical components to short circuit.
- Do not expose your body directly to cool air for a prolonged period of time.
- Do not allow children to play with the air conditioner. Children must be supervised around the unit at all times.
- If the air conditioner is used together with burners or other heating devices, thoroughly ventilate the room to avoid oxygen deficiency.
- In certain functional environments, such as kitchens, server rooms, etc., the use of specially designed air-conditioning units is highly recommended.

## **⚠ ELECTRICAL WARNINGS**

- Only use the specified power cord. If the power cord is damaged, it must be replaced by the manufacturer, its service agent or similarly qualified persons in order to avoid a hazard.
- The product must be properly grounded at the time of installation, or electrical shock may occur.
- For all electrical work, follow all local and national wiring standards, regulations, and the Installation Manual. Connect cables tightly, and clamp them securely to prevent external forces from damaging the terminal. Improper electrical connections can overheat and cause fire, and may also cause shock. All electrical connections must be made according to the Electrical Connection Diagram located on the panels of the indoor and outdoor units.
- All wiring must be properly arranged to ensure that the control board cover can close properly. If the control board cover is not closed properly, it can lead to corrosion and cause the connection points on the terminal to heat up, catch fire, or cause electrical shock.
- Disconnection must be incorporated in the fixed wiring in accordance with the wiring rules.
- Do not pull power cord to unplug unit. Hold the plug firmly and pull it from the outlet. Pulling directly on the cord can damage it, which can lead to fire or electric shock.
- Do not modify the length of the power supply cord or use an extension cord to power the unit.
- Do not share the electrical outlet with other appliances. Improper or insufficient power supply can cause fire or electrical shock.
- Keep power plug clean. Remove any dust or grime that accumulates on or around the plug. Dirty plugs can cause fire or electric shock.
- If connecting power to fixed wiring, an all-pole disconnection device which has at least 3mm clearances in all poles, and have a leakage current that may exceed 10mA, the residual current device(RCD) having a rated residual operating current not exceeding 30mA, and disconnection must be incorporated in the fixed wiring in accordance with the wiring rules.

## TAKE NOTE OF FUSE SPECIFICATIONS

The air conditioner's circuit board (PCB) is designed with a fuse to provide overcurrent protection. The specifications of the fuse are printed on the circuit board, such as : T3.15AL/250VAC, T5AL/250VAC, T3.15A/250VAC, T5A/250VAC, T20A/250VAC, T30A/250VAC,etc.

## UV-C lamp(Applicable to the unit contains an UV-C lamp only)

This appliance contains a UV-C lamp. Read the maintenance instructions before opening the appliance.

- Do not operate UV-C lamps outside of the appliance.
- Appliances that are obviously damaged must not be operated.
- Unintended use of the appliance or damage to the housing may result in the escape of dangerous UV-C radiation. UV-C radiation may, even in small doses, cause harm to the eyes and skin.
- Before opening doors and access panels bearing the ULTRAVIOLET RADIATION hazard symbol for the conducting USER MAINTENANCE, it is recommended to disconnect the power.
- The UV-C lamp can not be cleaned, repaired and replaced.
- UV-C BARRIERS bearing the ULTRAVIOLET RADIATION hazard symbol should not be removed.



### WARNING

This appliance contains an UV emitter. Do not stare at the light source.

## ⚠ WARNINGS FOR PRODUCT INSTALLATION

- Installation must be performed by an authorized dealer or specialist. Defective installation can cause water leakage, electrical shock, or fire.
- Installation must be performed according to the installation instructions. (In North America, installation must be performed in accordance with the requirement of NEC and CEC by authorized personnel only). Improper installation can cause water leakage, electrical shock, or fire.
- Contact an authorized service technician for repair or maintenance of this unit. This appliance shall be installed in accordance with national wiring regulations.
- Only use the included accessories, parts, and specified parts for installation. Using non-standard parts can cause water leakage, electrical shock, fire, and can cause the unit to fail.
- Install the unit in a firm location that can support the unit's weight. If the chosen location cannot support the unit's weight, or the installation is not done properly, the unit may drop and cause serious injury and damage.
- Install drainage piping according to the instructions in this manual. Improper drainage may cause water damage to your home and property.
- For units that have an auxiliary electric heater, do not install the unit within 1 meter (3 feet) of any combustible materials.
- Do not install the unit in a location that may be exposed to combustible gas leaks. If combustible gas accumulates around the unit, it may cause fire.
- Do not turn on the power until all work has been completed.
- When moving or relocating the air conditioner, consult experienced service technicians for disconnection and reinstallation of the unit.
- How to install the appliance to its support, please read the information for details in "indoor unit installation" and "outdoor unit installation" sections .

## CAUTION

- Turn off the air conditioner and disconnect the power if you are not going to use it for a long time.
- Turn off and unplug the unit during storms.
- Make sure that water condensation can drain unhindered from the unit.
- Do not operate the air conditioner with wet hands. This may cause electric shock.
- Do not use device for any other purpose than its intended use.
- Do not climb onto or place objects on top of the outdoor unit.
- Do not allow the air conditioner to operate for long periods of time with doors or windows open, or if the humidity is very high.

## CLEANING AND MAINTENANCE WARNINGS

- Turn off the device and disconnect the power before cleaning. Failure to do so can cause electrical shock.
- Do not clean the air conditioner with excessive amounts of water.
- Do not clean the air conditioner with combustible cleaning agents. Combustible cleaning agents can cause fire or deformation.

## Note about Fluorinated Gasses(Not applicable to the unit using R290 Refrigerant)

- This air-conditioning unit contains fluorinated greenhouse gasses. For specific information on the type of gas and the amount, please refer to the relevant label on the unit itself or the “Owner’s Manual - Product Fiche ” in the packaging of the outdoor unit. (European Union products only).
- Installation, service, maintenance and repair of this unit must be performed by a certified technician.
- Product uninstallation and recycling must be performed by a certified technician.
- For equipment that contains fluorinated greenhouse gases in quantities of 5 tonnes of CO<sub>2</sub> equivalent or more, but of less than 50 tonnes of CO<sub>2</sub> equivalent, If the system has a leak-detection system installed, it must be checked for leaks at least every 24 months.
- When the unit is checked for leaks, proper record-keeping of all checks is strongly recommended.

## WARNING FOR USING R32/R290 REFRIGERANT

- When flammable refrigerant are employed, appliance shall be stored in a well - ventilated area where the room size corresponds to the room area as specific for operation.  
For R32 frigerant models:
- Appliance shall be installed, operated and stored in a room with a floor area larger than 4m<sup>2</sup>.
- For R290 refrigerant models, appliance shall be installed, operated and stored in a room with a floor area larger than:
  - <=2.6kW units: 17.33m<sup>2</sup>
  - >2.6kW and <=3.5kW units: 25.4m<sup>2</sup>
  - >3.5kW and <=5.2kW units: 34.67m<sup>2</sup>
  - >5.3kW and <=7.1kW units: 47.33m<sup>2</sup>
- Reusable mechanical connectors and flared joints are not allowed indoors.

# SPECIFICATIONS

Product Model	CB1-09HRFN8-I/CB1-09HFNX-O	CB1-12HRFN8-I/CB1-12HFNX-O
Power source	220-240V~ 50Hz, 1Ph	
Cooling capacity	9500Btu/h	12000Btu/h
Heating capacity	10000Btu/h	13000Btu/h
Rated current	10.5A	10.5A
Rated power input	2200W	2200W
Refrigerant	R32/0.55kg	R32/0.62kg
Applicable room area(m <sup>2</sup> )	13	16

# PRODUCT OVERVIEW

## NOTE ON ILLUSTRATIONS:

Illustrations in this manual are for explanatory purposes. The actual shape of your indoor unit may be slightly different. The actual shape shall prevail.

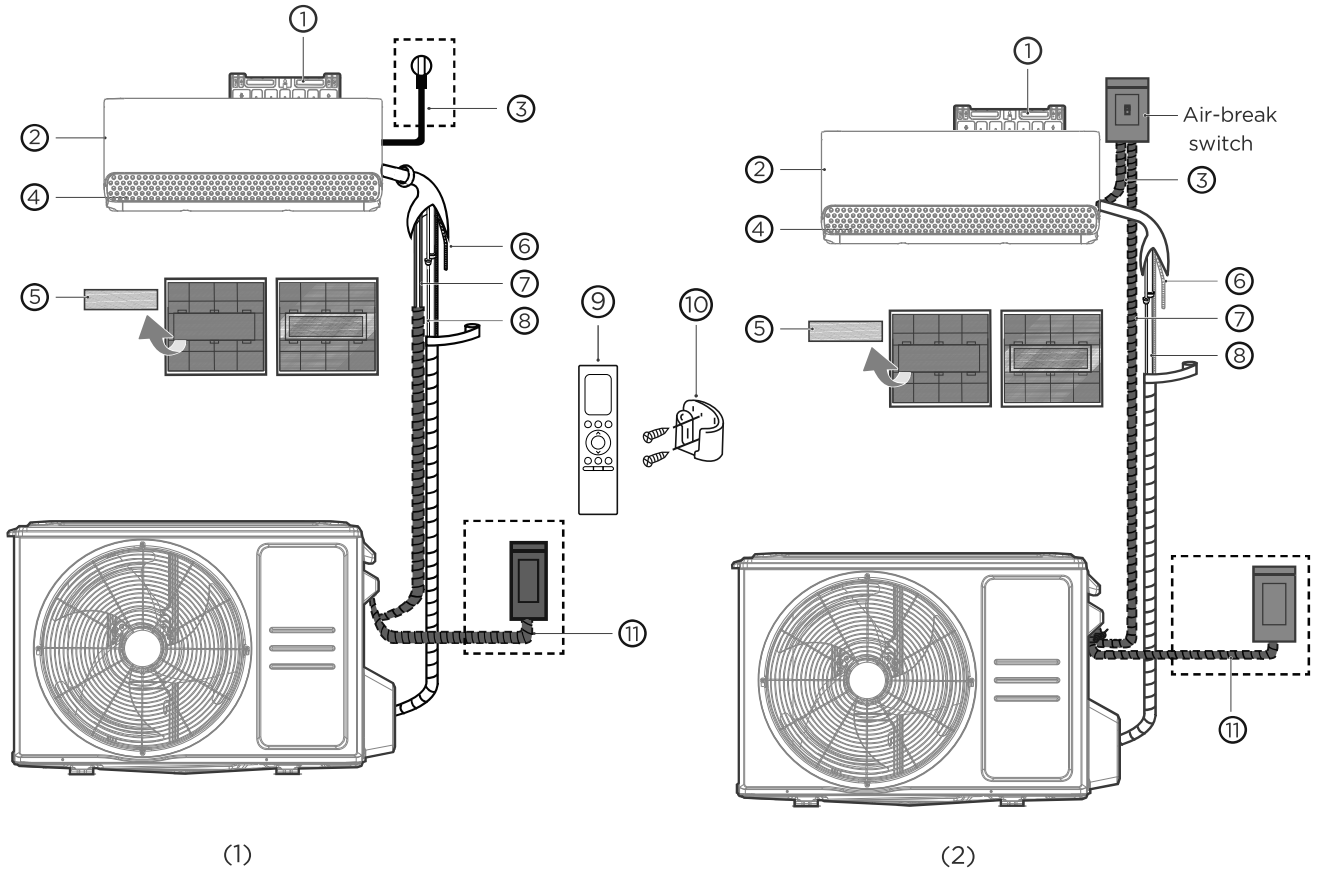

① Wall Mounting Plate

② Front Panel

③ Power Cable(some units)

④ Louver

⑤ Functional Filter (On Back of Main Filter - Some Units)

⑥ Drainage Pipe

⑦ Signal Cable

⑧ Refrigerant Piping

⑨ Remote Controller

⑩ Remote controller Holder (not supplied)











⑪ Outdoor Unit Power Cable (some units)



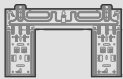

# PRODUCTION INSTALLATION

## ACCESSORIES

The air conditioning system comes with the following accessories. Use all of the installation parts and accessories to install the air conditioner. Improper installation may result in water leakage, electrical shock and fire, or cause the equipment to fail. The items are not included with the air conditioner must be purchased separately.

Name of Accessories	Q'ty(pc)	Shape	Name of Accessories	Q'ty(pc)	Shape
Manual	1-3		Remote controller	1	
Drain joint (for cooling & heating models)	1		Battery	2	
Seal (for cooling & heating models)	1		Remote controller holder (purchase separately)	1	
Mounting plate	1		Fixing screw for remote controller holder (purchase separately)	2	
Anchor	5-8 (depending on models)		<b>Small Filter</b> (Need to be installed on the back of main air filter by the authorized technician while installing the machine)	1-2 (depending on models)	
Mounting plate fixing screw	5-8 (depending on models)				

Name	Shape	Quantity(PC)	
Connecting pipe assembly	Liquid side	Φ 6.35(1/4in)	Parts you must purchase separately. Consult the dealer about the proper pipe size of the unit you purchased.
		Φ 9.52(3/8in)	
	Gas side	Φ 9.52(3/8in)	
		Φ 12.7(1/2in)	
		Φ 16(5/8in)	
Magnetic ring and belt (if supplied, please refer to the wiring diagram to install it on the connective cable.)		 Pass the belt through the hole of the Magnetic ring to fix it on the cable	Varies by model

### It would be perfect you had these tools



Gloves



Screwdriver & wrench

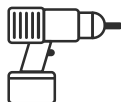

Percussion drill

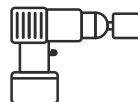

Water drill



Goggles & masks



Vinyl tape

# INSTALLATION SUMMARY - INDOOR UNIT

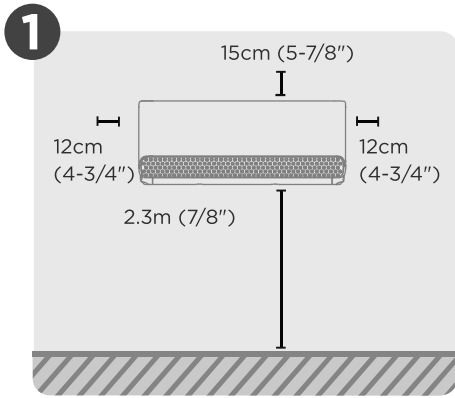

Select Installation Location

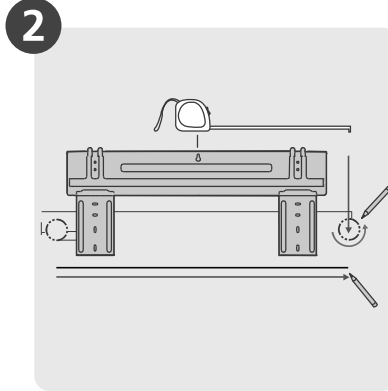

Attach Mounting Plate

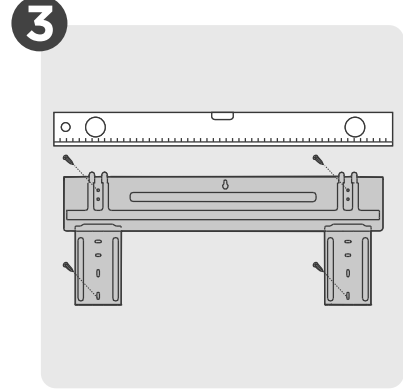

Determine Wall Hole Position

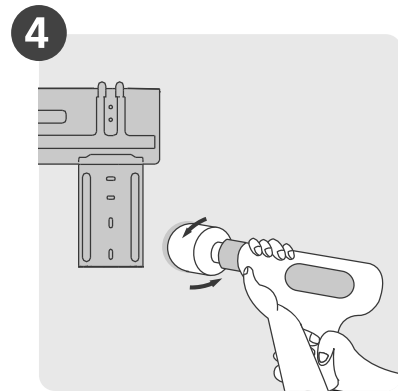

Drill Wall Hole

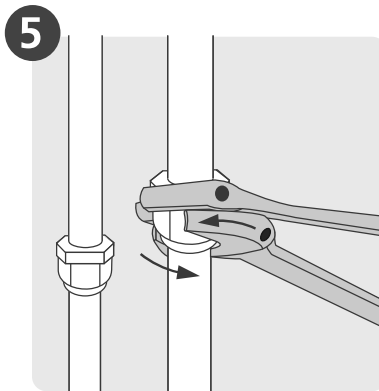

Connect Piping

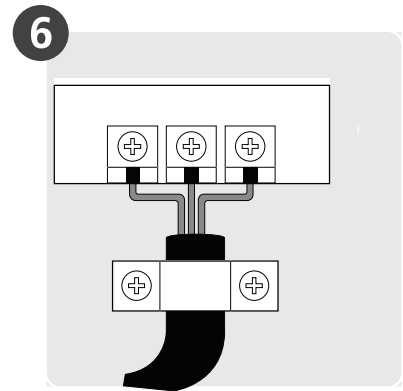

Connect Wiring  
(Not applicable for some locations in North America)

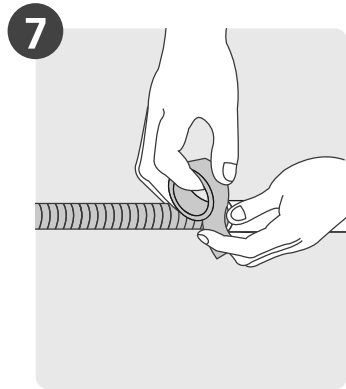

Prepare Drain Hose

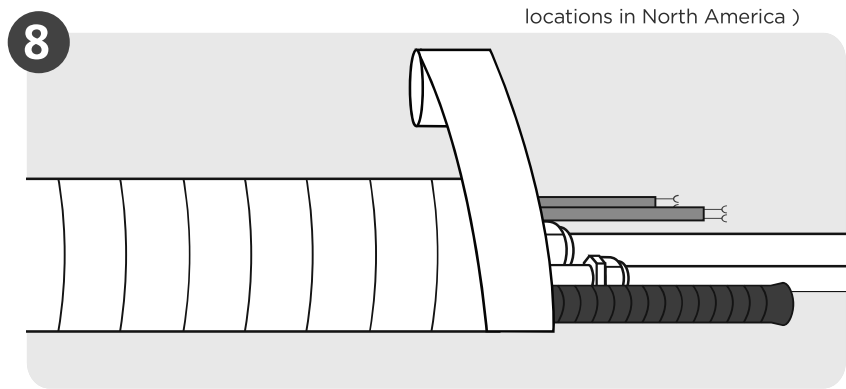

Wrap Piping and Cable  
(Not applicable for some locations in North America)

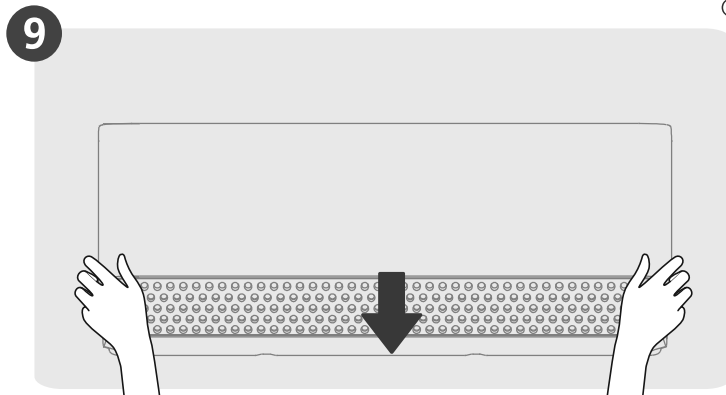

Mount Indoor Unit

# Install Your Indoor Unit

## 1 Select installation location

### **NOTE : Prior to installation**

Before installing the indoor unit, refer to the label on the product box to make sure that the model number of the indoor unit matches the model number of the outdoor unit.

The following are standards that will help you choose an appropriate location for the unit.

#### **Proper installation locations meet the following standards:**



Good air circulation

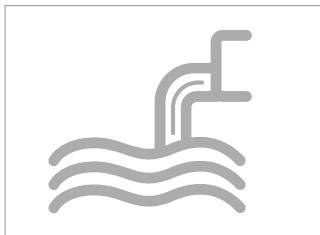

Convenient drainage



Noise from the unit will not disturb other people.

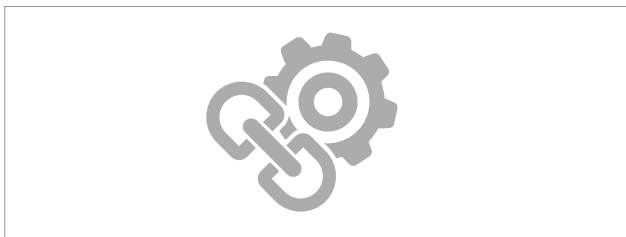

- Firm and solid—the location will not vibrate
- Strong enough to support the weight of the unit

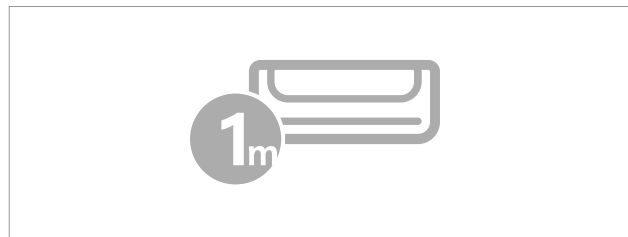

- A location at least one meter from all other electrical devices (e.g., TV, radio, computer)

#### **DO NOT install unit in the following locations:**

- Near any source of heat, steam, or combustible gas
- Near any obstacle that might block air circulation
- Near flammable items such as curtains or clothing
- Near the doorway
- In a location subject to direct sunlight

### **NOTE: FOR PRODUCT INSTALLATION**

If there is no fixed refrigerant piping:

While choosing a location, be aware that you should leave ample room for a wall hole (see Drill wall hole for connective piping step) for the signal cable and refrigerant piping that connect the indoor and outdoor units. The default position for all piping is the right side of the indoor unit (while facing the unit). However, the unit can accommodate piping to both the left and right.

## 2

## Drill wall hole for connective piping

### Determine wall hole location

#### **NOTE : The wall hole size**

The size of the wall hole is determined by the connective pipes. When the size of the gas side connective pipe is  $\Phi 16\text{mm}$ (5/8") or more, the wall hole should be 90mm(3-9/16"). For the size of connective pipe is less than  $\Phi 16\text{mm}$ (5/8"), the wall hole should be 65mm(2-1/2").

#### Step 1:

Remove the screw that attaches the mounting plate to the back of the indoor unit.

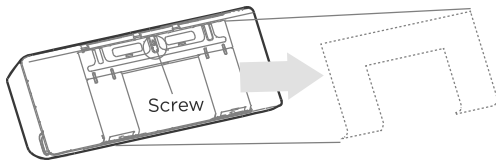

#### Step 2:

Different models have different mounting plates. For the different customization requirements, the shape of the mounting plate may be slightly different. But the installation dimensions are the same for the same size of indoor unit. See Type A and Type B for example.

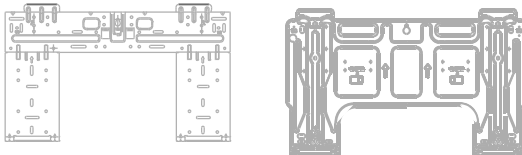

Type A

Type B

#### Step 3:

Secure the mounting plate to the wall with the screws provided. Make sure that mounting plate is flat against the wall.

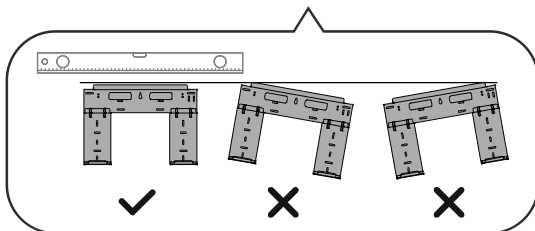

Correct orientation of Mounting Plate

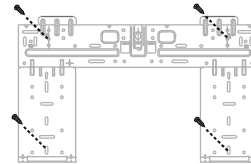

#### **NOTE : FOR CONCRETE OR BRICK WALLS**

If the wall is made of brick, concrete, or similar material, drill 5mm-diameter (0.2in-diameter) holes in the wall and insert the sleeve anchors provided. Then secure the mounting plate to the wall by tightening the screws directly into the clip anchors.

#### Step 4:

Confirm the mounting plate you own. Determine the location of the wall hole based on the position of the mounting plate. The dotted rectangular box above shows the size of your product.

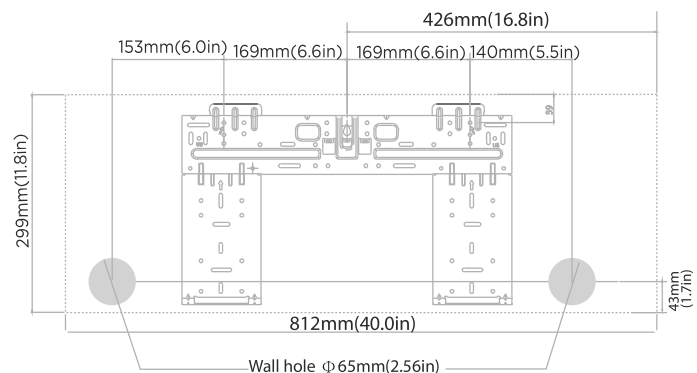

**Indoor unit demensions(WxH):**  
812mm(40.0in)x299mm(11.8in)

**CAUTION**

When drilling the wall hole, make sure to avoid wires, plumbing, and other sensitive components.

**Drill wall hole**

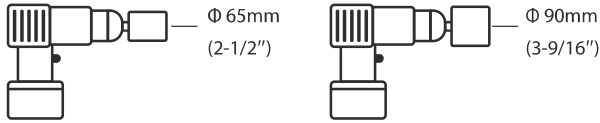

Using a 65mm (2-1/2") or 90mm(3-9/16") core drill(depending on models )

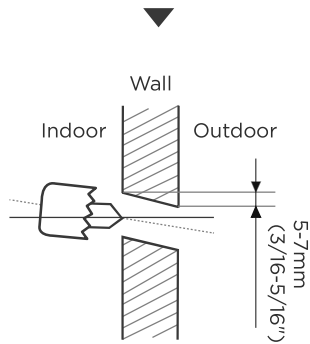

**Step 1:**

Using a 65mm (2.5") or 90mm(3.54") core drill(depending on models ), drill a hole in the wall. Make sure that the hole is drilled at a slight downward angle, so that the outdoor end of the hole is lower than the indoor end by about 5mm to 7mm (3/16-5/16"). This will ensure proper water drainage.

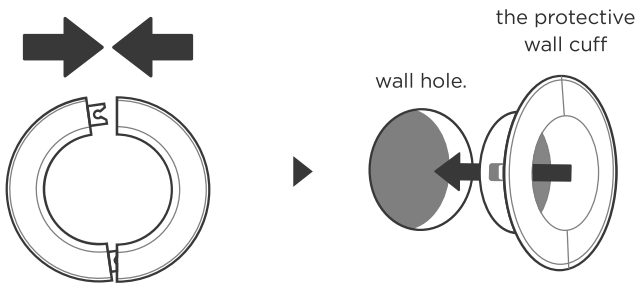

Place the protective wall cuff in the hole.

**Step 2:**

Place the protective wall cuff in the hole. This protects the edges of the hole and will help seal it when you finish the installation process.

### 3 Install refrigerant pipe & drain hose

#### NOTE

The refrigerant piping is inside an insulating sleeve attached to the back of the unit. You must prepare the piping before passing it through the hole in the wall.

#### Prepare refrigerant piping

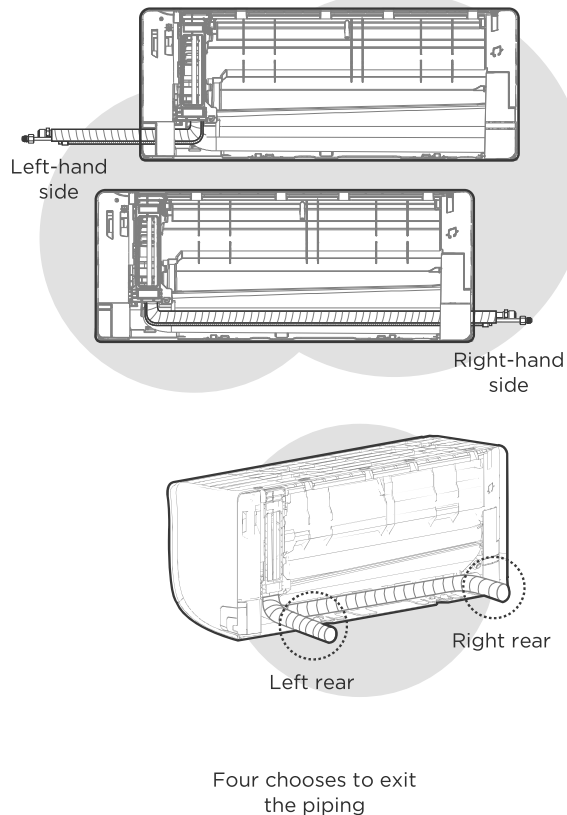

#### Step 1:

Based on the position of the wall hole relative to the mounting plate, choose the side from which the piping will exit the unit. You have four options for the exit direction of the piping. The description of the piping angle below for details.

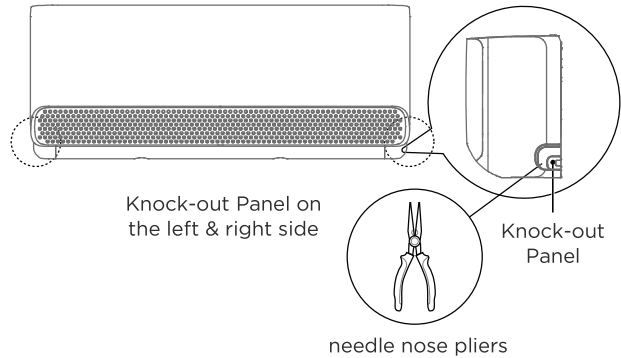

#### Step 2:

If the wall hole is behind the unit, keep the knock-out panel in place. If the wall hole is to the side of the indoor unit, remove the plastic knock-out panel from that side of the unit. Use needle nose pliers if the plastic panel is too difficult to remove by hand.

**Note:** Groove has been made in the knock-out panel in order to cut it conveniently. The size of the slot is determined by the diameter of pipings.

#### Step 3:

connect the indoor unit's refrigerant piping to the connective piping that will join the indoor and outdoor units. Refer to the **Refrigerant Piping Connection** section of this manual for detailed instructions.

**NOTE:** If existing connective piping is already embedded in the wall, proceed directly to the **Connect Drain Hose** step.

#### CAUTION

Be extremely careful not to dent or damage the piping while bending them away from the unit. Any dents in the piping will affect the unit's performance.

## Connect drain hose

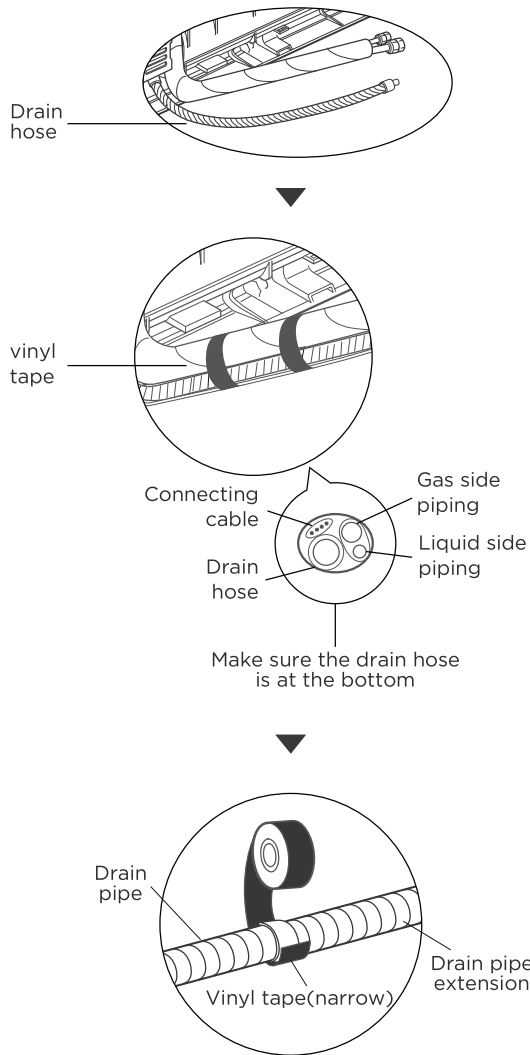

### Step 1:

The drain hose can be attached to the left or right side. To ensure proper drainage, attach the drain hose on the same side that your refrigerant piping exits the unit. Attach drain hose extension (purchased separately) to the end of drain hose.

- Wrap the connection point firmly with Teflon tape to ensure a good seal and to prevent leaks.

- For the portion of the drain hose that will remain indoors, wrap it with foam pipe insulation to prevent condensation.
- Remove the air filter and pour a small amount of water into the drain pan to make sure that water flows from the unit smoothly.



### NOTE ON DRAIN HOSE PLACEMENT

Make sure to arrange the drain hose according to the following figures.

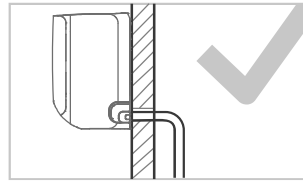

#### CORRECT

Make sure there are no kinks or dent in drain hose to ensure proper drainage.

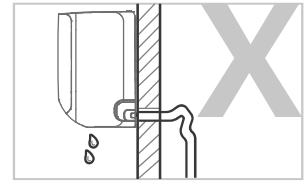

#### NOT CORRECT

Kinks in the drain hose will create water traps.

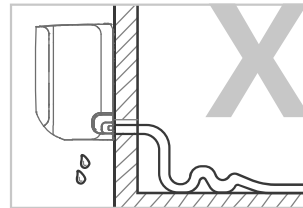

#### NOT CORRECT

Kinks in the drain hose will create water traps.

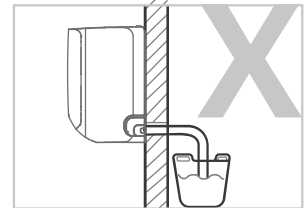

#### NOT CORRECT

Do not place the end of the drain hose in water or in containers that collect water. This will prevent proper drainage.



### CAUTION

#### PLUG THE UNUSED DRAIN HOLE

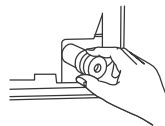

To prevent unwanted leaks you must plug the unused drain hole with the rubber plug provided.

**WARNING**

- **BEFORE PERFORMING ANY ELECTRICAL WORK, READ THESE REGULATIONS**
- **BEFORE PERFORMING ANY ELECTRICAL OR WIRING WORK, TURN OFF THE MAIN POWER TO THE SYSTEM.**

1. All wiring must comply with local and national electrical codes, regulations and must be installed by a licensed electrician.
2. All electrical connections must be made according to the Electrical Connection Diagram located on the panels of the indoor and outdoor units.
3. If there is a serious safety issue with the power supply, stop work immediately. Explain your reasoning to the client, and refuse to install the unit until the safety issue is properly resolved.
4. If connecting power to fixed wiring, a switch or circuit breaker that disconnects all poles and has a contact separation of at least 1/8in (3mm) must be incorporated in the fixed wiring. The qualified technician must use an approved circuit breaker or switch.
5. Only connect the unit to an individual branch circuit outlet. Do not connect another appliance to that outlet.
6. Make sure to properly ground the air conditioner.
7. Every wire must be firmly connected. Loose wiring can cause the terminal to overheat, resulting in product malfunction and possible fire.
8. Do not let wires touch or rest against refrigerant tubing, the compressor, or any moving parts within the unit.
9. To avoid getting an electric shock, never touch the electrical components soon after the power supply has been turned off. After turning off the power, always wait 10 minutes or more before you touch the electrical components.
10. Power voltage should be within 90-110% of rated voltage. Insufficient power supply can cause malfunction, electrical shock, or fire.

**WARNING**

All wiring must be performed strictly in accordance with the wiring diagram located on the back of the Indoor Unit's front panel.

**Connect signal and power cables**

The signal cable enables communication between the indoor and outdoor units. You must first choose the right cable size before preparing it for connection.

**Cable Types(Not applicable for North America)**

- Indoor Power Cable (if applicable): H05VV-F or H05V2V2-F
- Outdoor Power Cable: H07RN-F or H05RN-F
- Signal Cable: H07RN-F

**Minimum Cross-Sectional Area of Power and Signal Cables (For reference)**

Rated Current of Appliance (A)	Nominal Cross-Sectional Area (mm <sup>2</sup> )
> 3 and ≤ 6	0.75
> 6 and ≤ 10	1
> 10 and ≤ 16	1.5
> 16 and ≤ 25	2.5
> 25 and ≤ 32	4
> 32 and ≤ 40	6

**CHOOSE THE RIGHT CABLE SIZE**

The size of the power supply cable, signal cable, fuse, and switch needed is determined by the maximum current of the unit. The maximum current is indicated on the nameplate located on the side panel of the unit. Refer to this nameplate to choose the right cable, fuse, or switch.

1. Open front panel of the indoor unit.
2. Using a screwdriver, open the wire box cover on the right side of the unit. This will reveal the terminal block.
3. Unscrew the cable clamp below the terminal block and place it to the side.



4. Facing the back of the unit, remove the plastic panel on the bottom left-hand side.
5. Feed the signal wire through this slot, from the back of the unit to the front.
6. Facing the front of the unit, connect the wire according to the indoor unit's wiring diagram, connect the u-lug and firmly screw each wire to its corresponding terminal.
7. After checking to make sure every connection is secure, use the cable clamp to fasten the signal cable to the unit. Screw the cable clamp down tightly.
8. Replace the wire cover on the front of the unit, and the plastic panel on the back.

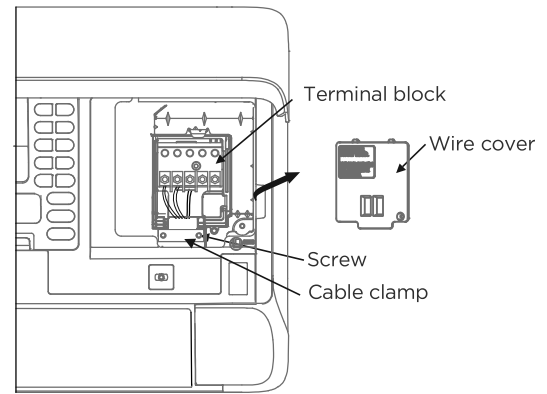

### In North America

**NOTE:** Choose the cable type according to the local electrical codes and regulations. Please choose the right cable size according to the Minimum Circuit Ampacity indicated on the nameplate of the unit.

1. Facing the back of the unit, remove the plastic panel on the bottom left-hand side.
2. As shown in the illustration, insert the wires including the ground wire into the conduit and secure them with lock nut onto the conduit mounting plate.
3. Match wire colors with terminal numbers on indoor and outdoor unit's terminal blocks and firmly screw wires to the corresponding terminals.
4. Connect the ground wires to the corresponding terminals.
5. Pull the wires and check that the wires are securely fixed to the terminal block.

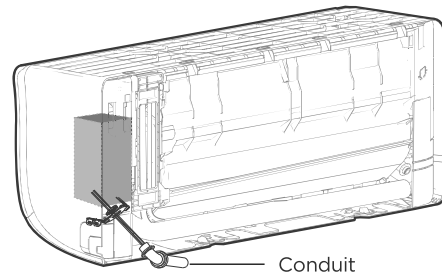

### **DO NOT MIX UP LIVE AND NULL WIRES**

This is dangerous, and can cause the air conditioning unit to malfunction.

## 5

## Wrap piping & Cables

### NOTE

Before passing the piping, and drain hose and the signal cable through the wall hole, you must bundle them together to save space, protect them, and insulate them.

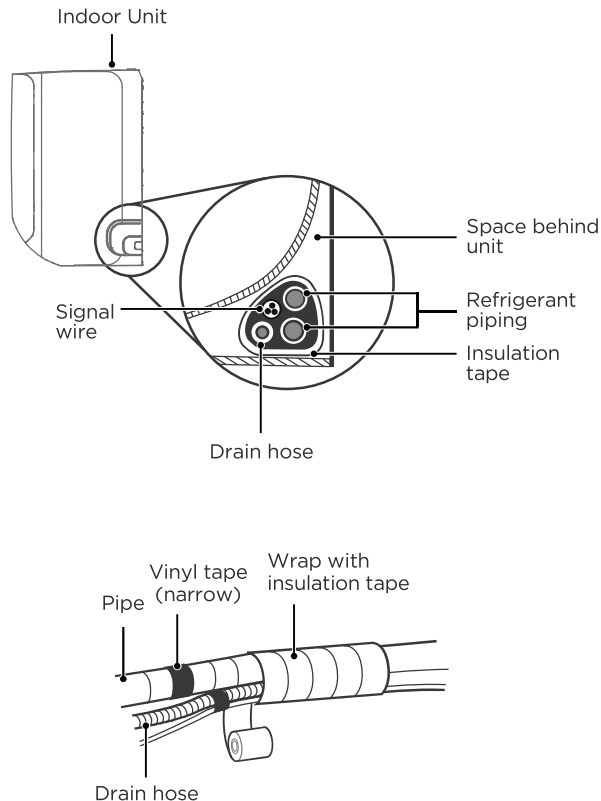

#### Step 1:

Bundle the drain hose, refrigerant pipes, and signal cable as shown in the figure (Not applicable for some locations in North America).

#### Step 2:

Using adhesive vinyl tape, attach the drain hose to the underside of the refrigerant pipes.

#### Step 3:

Using insulation tape, wrap the refrigerant pipes, signal wire and drain hose tightly together. Double-check that all items are bundled.

### **Do not intertwine signal cable with other wires**

While bundling these items together, do not intertwine or cross the signal cable with any other wiring.

### **DRAIN HOSE MUST BE ON BOTTOM**

Make sure that the drain hose is at the bottom of the bundle. Putting the drain hose at the top of the bundle can cause the drain pan to overflow, which can lead to fire or water damage.

### **DO NOT WRAP ENDS OF PIPING**

When wrapping the bundle, keep the ends of the piping unwrapped. You need to access them to test for leaks at the end of the installation process (refer to Electrical Checks and Leak Checks section of this manual).

## 6

## Mount indoor unit

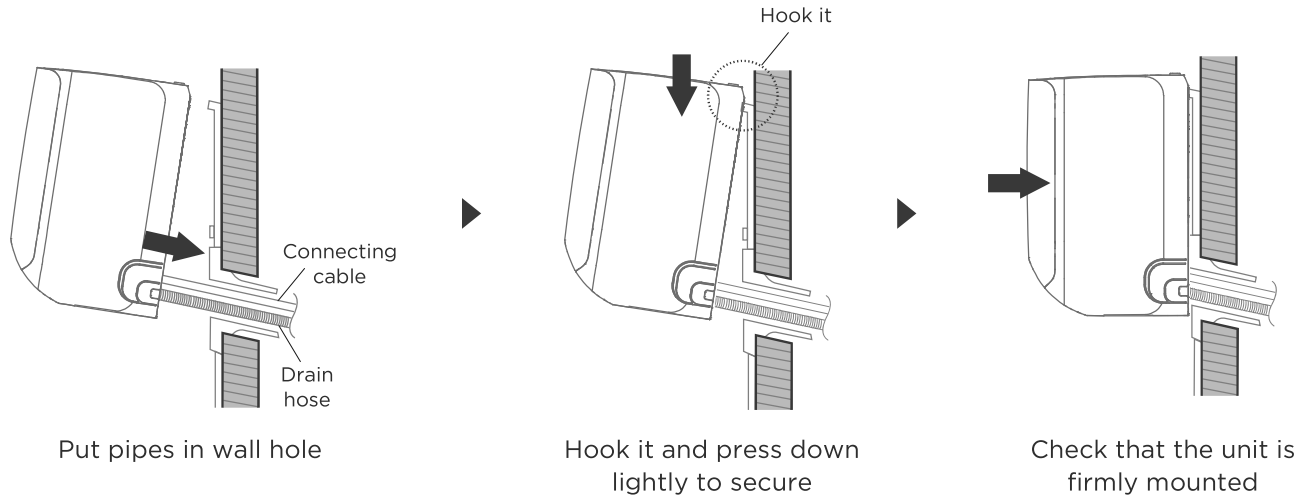

**If you installed new connective piping to the outdoor unit, do the following:**

- If you have already passed the refrigerant piping through the hole in the wall, proceed to Step 4.
- Otherwise, double-check that the ends of the refrigerant pipes are sealed to prevent dirt or foreign materials from entering the pipes.
- Slowly pass the wrapped bundle of refrigerant pipes, drain hose, and signal wire through the hole in the wall.
- Hook the top of the indoor unit on the upper hook of the mounting plate.
- Check that unit is hooked firmly on mounting by applying slight pressure to the left and right-hand sides of the unit. The unit should not jiggle or shift.
- Using even pressure, push down on the bottom half of the unit. Keep pushing down until the unit snaps onto the hooks along the bottom of the mounting plate.
- Again, check that the unit is firmly mounted by applying slight pressure to the left and the right-hand sides of the unit.

**If refrigerant piping is already embedded in the wall, do the following:**

- Hook the top of the indoor unit on the upper hook of the mounting plate.
- Use a bracket or wedge to prop up the unit, giving you enough room to connect the refrigerant piping, signal cable, and drain hose.
- Connect drain hose and refrigerant piping (refer to **Refrigerant Piping Connection** section of this manual for instructions).
- Keep pipe connection point exposed to perform the leak test (refer to **Electrical Checks** and **Leak Checks** section of this manual).
- After the leak test, wrap the connection point with insulation tape.
- Remove the bracket or wedge that is propping up the unit.
- Using even pressure, push down on the bottom half of the unit. Keep pushing down until the unit snaps onto the hooks along the bottom of the mounting plate.

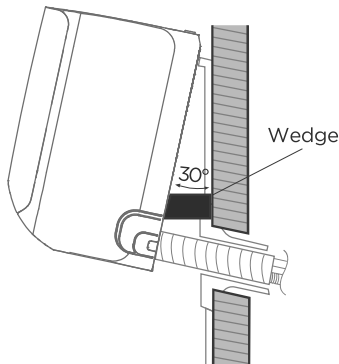

**NOTE : UNIT IS ADJUSTABLE**

Keep in mind that the hooks on the mounting plate are smaller than the holes on the back of the unit. If you find that you don't have ample room to connect embedded pipes to the indoor unit, the unit can be adjusted left or right by about 30-50mm (1.18-1.96in), depending on the model.

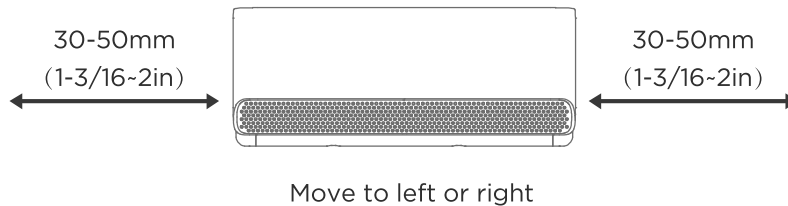

**CAUTION**

For the units adopt the following pipe connectors, please strictly perform the piping work in accordance with the following instructions.

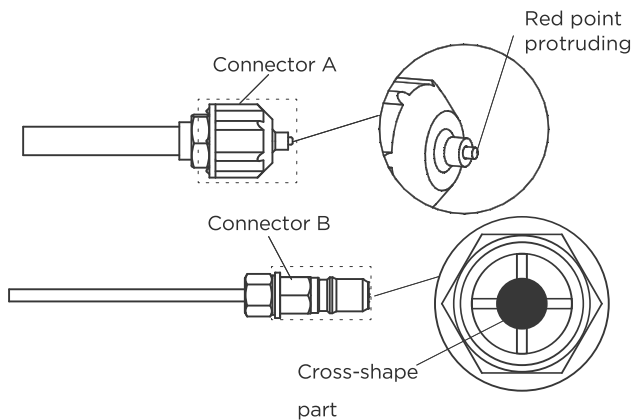

- Before performing the refrigerant piping connection, always wear work gloves and goggles, and remember that the connectors A and B are not allowed to face people directly.
- Keep pressing the cross-shape part of connector B with a tool for about 5-10 seconds until the red protruding point of connector A retracts completely.
- Remove connectors A and B, then perform the refrigerant piping connection between indoor unit and outdoor unit.

# Install Your Outdoor Unit

## 1 Select installation location

### **NOTE : PRIOR TO INSTALLATION**

Before installing the outdoor unit, you must choose an appropriate location. The following are standards that will help you choose an appropriate location for the unit.

#### Proper installation locations meet the following standards:

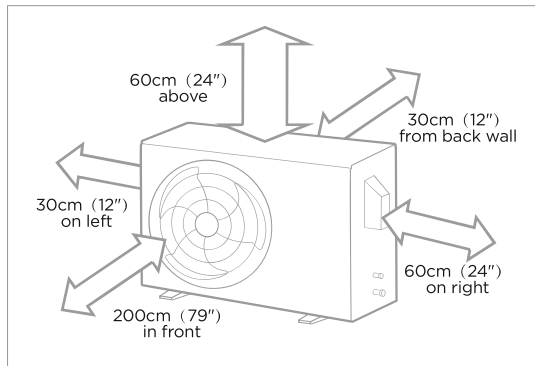

Good air circulation and ventilation.



Firm and solid—the location can support the unit and will not vibrate.



Noise from the unit will not disturb other people.



Protected from prolonged periods of direct sunlight or rain.



Where snowfall is anticipated, take appropriate measures to prevent ice buildup and coil damage.

Meets all spatial requirements shown in Installation Space Requirements above.

**NOTE** Install the unit by following local codes and regulations, there may be differ slightly between different regions.

### **CAUTION:**

#### SPECIAL CONSIDERATIONS FOR EXTREME WEATHER

##### If the unit is exposed to heavy wind:

Install unit so that air outlet fan is at a 90° angle to the direction of the wind. If needed, build a barrier in front of the unit to protect it from extremely heavy winds. See Figures below.

##### If the unit is frequently exposed to heavy rain or snow:

Build a shelter above the unit to protect it from the rain or snow. Be careful not to obstruct air flow around the unit.

##### If the unit is frequently exposed to salty air(seaside):

Use outdoor unit that is specially designed to resist corrosion.

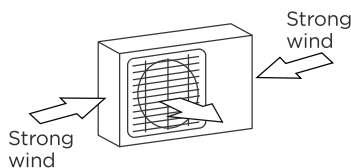

90° angle to the direction of the wind

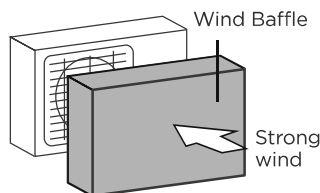

Build a wind Baffle to protect the unit

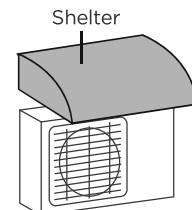

Build a shelter to protect the unit

#### DO NOT install unit in the following locations:

- Near an obstacle that will block air inlets and outlets.
- Near animals or plants that will be harmed by hot air discharge.
- In a location that is exposed to large amounts of dust
- Near a public street, crowded areas, or where noise from the unit will disturb others.
- Near any source of combustible gas.
- In a location exposed to a excessive amounts of salty air.

## 2

### Install drain joint(Heat pump unit only)

#### **NOTE : PRIOR TO INSTALLATION**

Before bolting the outdoor unit in place, you must install the drain joint at the bottom of the unit. For the units with base pan built-in with multiple holes for proper draining during defrost, the drain joint is no need to be installed.

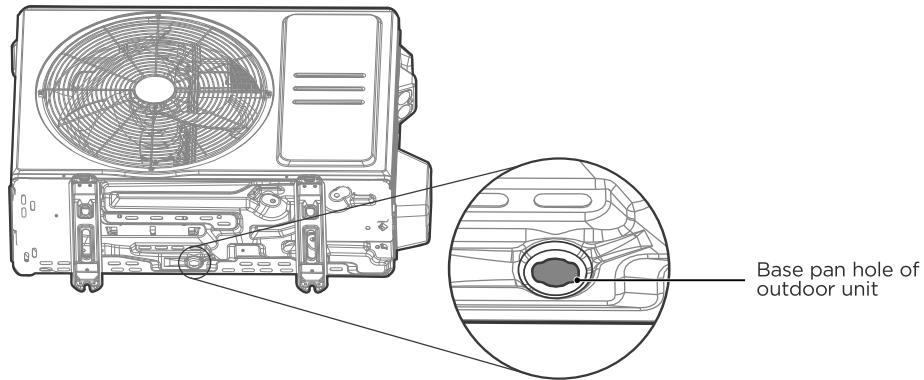

#### **Step 1:**

Find out the base pan hole of outdoor unit.

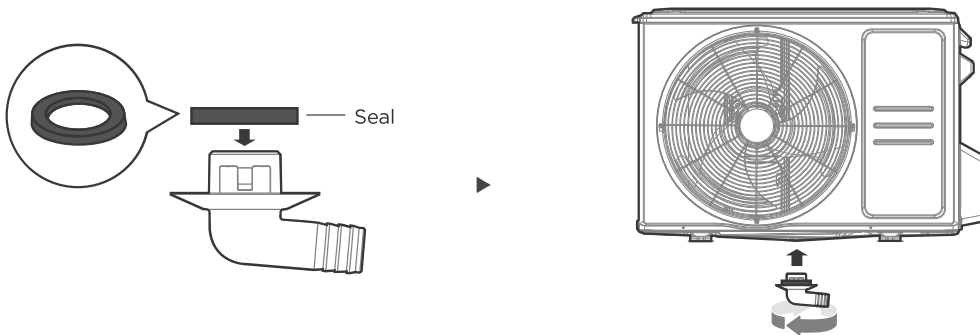

#### **Step 2:**

- Fit the rubber seal on the end of the drain joint that will connect to the outdoor unit.
- Insert the drain joint into the hole in the base pan of the unit. The drain joint will click in place.
- Connect a drain hose extension (not included) to the drain joint to redirect water from the unit during heating mode.

#### **NOTE : IN COLD CLIMATES**

In cold climates, make sure that the drain hose is as vertical as possible to ensure swift water drainage. If water drains too slowly, it can freeze in the hose and flood the unit.

### 3

## Anchor Outdoor Unit

### ⚠ WARNING

**WHEN DRILLING INTO CONCRETE, EYE PROTECTION IS RECOMMENDED AT ALL TIME.**

- The outdoor unit can be anchored to the ground or to a wall-mounted bracket with bolt(M10). Prepare the installation base of the unit according to the dimensions below.
- The following is a list of different outdoor unit sizes and the distance between their mounting feet. Prepare the installation base of the unit according to the dimensions below.

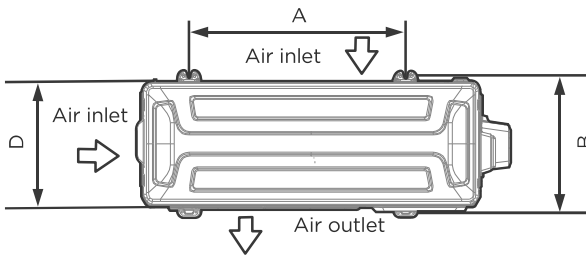

Top view

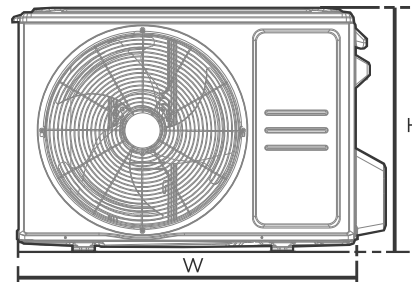

Front view

Outdoor Unit Dimensions (mm) W x H x D	Mounting Dimensions	
	Distance A (mm)	Distance B (mm)
680x542x248 (26.8"x 21.3"x 9.8")	452 (17.8")	230 (9.1")
720x495x270 (28.3"x 19.5"x 10.6")	452 (17.8")	255 (10.0")
765x555x303 (30.1"x 21.8"x 11.9")	452 (17.8")	286(11.3")
805x554x330 (31.7"x 21.8"x 12.9")	511 (20.1")	317 (12.5")
890x673x342 (35.0"x 26.5"x 13.5")	663 (26.1")	354 (13.9")
946x810x420 (37.2"x 31.9"x 16.5")	673 (26.5")	403 (15.9")
946x810x410 (37.2"x 31.9"x 16.1")	673 (26.5")	403 (15.9")

#### If you will install the unit on the ground or on a concrete mounting platform, do the following:

- Mark the positions for four expansion bolts based on dimensions chart.
- Pre-drill holes for expansion bolts.
- Place a nut on the end of each expansion bolt.
- Hammer expansion bolts into the pre-drilled holes.
- Remove the nuts from expansion bolts, and place outdoor unit on bolts.
- Put washer on each expansion bolt, the replace the nuts.
- Using a wrench, tighten each nut until snug.

#### If you will install the unit on a wall-mounted bracket , do the following:

- Mark the position of bracket holes based on dimensions chart.
- Pre-drill the holes for the expansion bolts.
- Place a washer and nut on the end of each expansion bolt.
- Thread expansion bolts through holes in mounting brackets, put mounting brackets in position, and hammer expansion bolts into the wall.
- Check that the mounting brackets are level.
- Carefully lift unit and place its mounting feet on brackets.
- Bolt the unit firmly to the brackets.
- If allowed, install the unit with rubber gaskets to reduce vibrations and noise.

### ⚠ CAUTION

Make sure that the wall is made of solid brick, concrete, or of similarly strong material. The wall must be able to support at least four times the weight of the unit.

### **⚠️ WARNING - Before the Operation**

- ALL WIRING WORK MUST BE PERFORMED STRICTLY IN ACCORDANCE WITH THE WIRING DIAGRAM LOCATED INSIDE OF WIRE COVER OF THE OUTDOOR UNIT.
- BEFORE PERFORMING ANY ELECTRICAL OR WIRING WORK, TURN OFF THE MAIN POWER TO THE SYSTEM.

### Prepare the cable for connection

Please choose the right cable according to the “Cable types” in page 24.

- Using wire strippers, strip the rubber jacket from both ends of cable to reveal about 40mm (1.57in) of the wires inside.
- Strip the insulation from the ends of the wires.
- Using a wire crimper, crimp u-lugs on the ends of the wires.

### Pay attention to live wire

While crimping wires, make sure you clearly distinguish the Live (“L”) Wire from other wires.

The outside unit’s terminal block is protected by an electrical wiring cover on the side of the unit. A comprehensive wiring diagram is printed on the inside of the wiring cover.

- Unscrew the electrical wiring cover and remove it.
- Unscrew the cable clamp below the terminal block and place it to the side.
- Connect the wire according to the wiring diagram, and firmly screw the u-lug of each wire to its corresponding terminal.
- After checking to make sure every connection is secure, loop the wires around to prevent rain water from flowing into the terminal.
- Using the cable clamp, fasten the cable to the unit. Screw the cable clamp down tightly.
- Insulate unused wires with PVC electrical tape. Arrange them so that they do not touch any electrical or metal parts.
- Replace the wire cover on the side of the unit, and screw it in place.

**NOTE:** If the cable clamp looks like the following, please select the appropriate through-hole according to the diameter of the wire.

### Choose the right cable size

The size of the power supply cable, signal cable, fuse, and switch needed is determined by the maximum current of the unit. The maximum current is indicated on the nameplate located on the side panel of the unit.

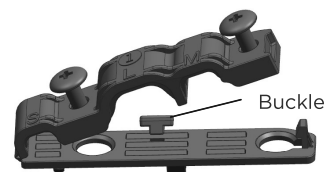
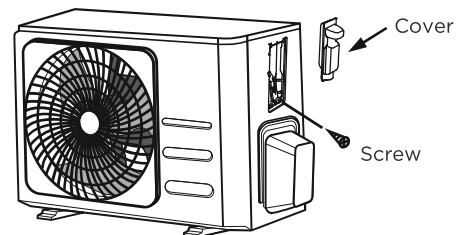

Three size hole: Small, Large, Medium

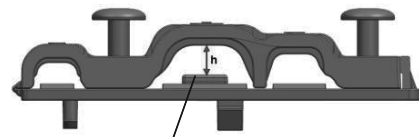

When the cable is not fasten enough, use the buckle to prop it up, so it can be clamped tightly.



## In North America

The outside unit's terminal block is protected by an electrical wiring cover on the side of the unit. A comprehensive wiring diagram is stuck on the inside of the wiring cover.

- Remove the wire cover from the unit by loosening the 3 screws.
- Dismount caps on the conduit panel.
- Temporarily mount the conduit tubes(not included) on the conduit panel.
- Properly connect both the power supply and low voltage lines to the corresponding terminals on the terminal block.
- Ground the unit in accordance with local codes.
- Be sure to size each wire allowing several inches longer than the required length for wiring.
- Use lock nuts to secure the conduit tubes.

**NOTE:** Please choose the right cable size according to the Minimum Circuit Ampacity indicated on the nameplate of the unit.

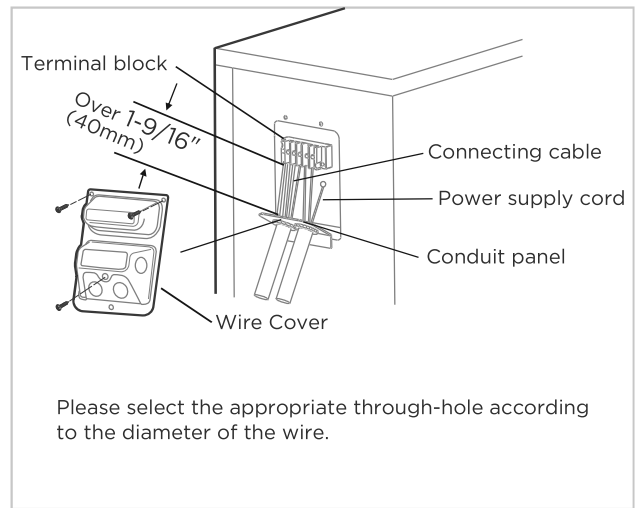

## How to properly connect the wire lines.

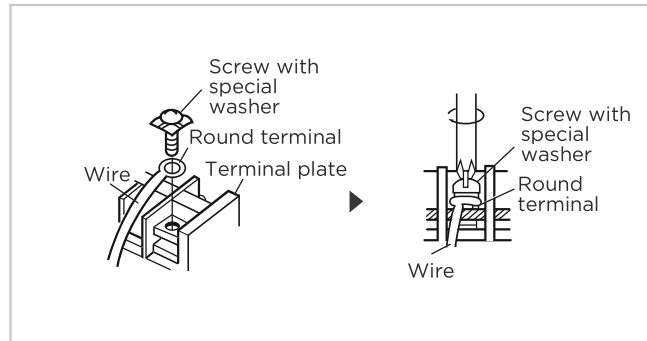
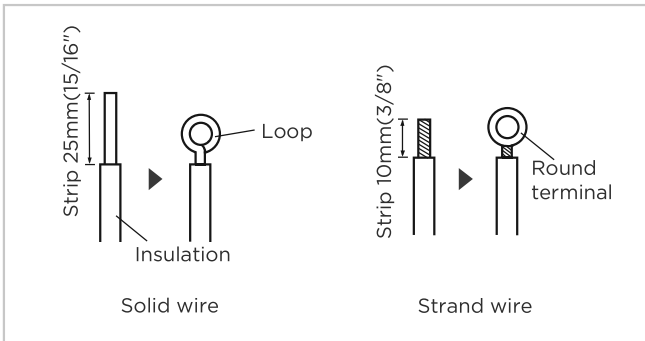

### Step 1:

The treatment about the end of the wire.

### Step 2:

connecting the line to the corresponding terminals on the terminal block.

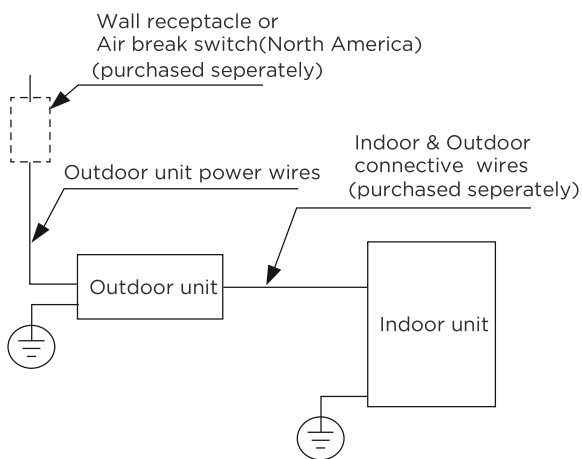

(A)

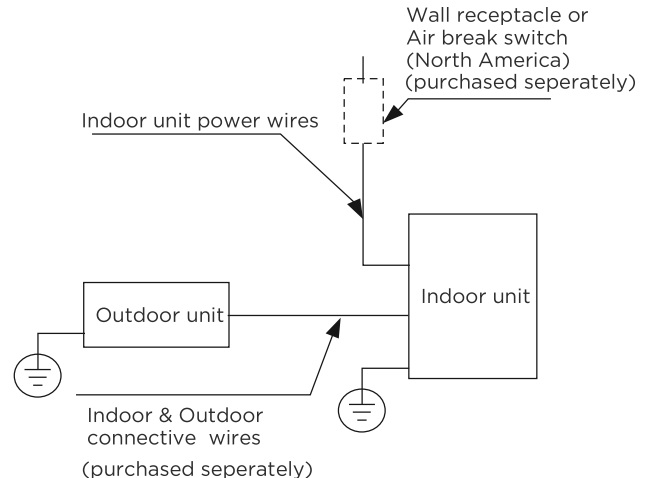

(B)

# Refrigerant Piping Connection

1

## Piping Connection Precautions

### ⚠ WARNING

WHEN CONNECTING REFRIGERANT PIPING, **DO NOT** LET SUBSTANCES OR GASES OTHER THAN THE SPECIFIED REFRIGERANT ENTER THE UNIT. THE PRESENCE OF OTHER GASES OR SUBSTANCES WILL LOWER THE UNIT'S CAPACITY, AND CAN CAUSE ABNORMALLY HIGH PRESSURE IN THE REFRIGERATION CYCLE. THIS CAN CAUSE EXPLOSION AND INJURY.

### Note on Pipe Length

The length of refrigerant piping will affect the performance and energy efficiency of the unit. Nominal efficiency is tested on units with a pipe length of 5 meters (16.5ft). A minimum pipe run of 3 metres is required to minimise vibration & excessive noise. Connection Instructions - Refrigerant Piping.

#### Maximum Length and Drop Height of Refrigerant Piping per Unit Model

Model	Capacity (BTU/h)	Max. Length (m)	Max. Drop Height (m)
R410A,R32 Inverter Split Air Conditioner	< 15,000	25 (82ft)	10 (33ft)
	≥ 15,000 and < 24,000	30 (98.5ft)	20 (66ft)
	≥ 24,000 and < 36,000	50 (164ft)	25 (82ft)
	≥ 36,000 and < 60,000	65 (213ft)	30 (98.5ft)
R22 Fixed-speed Split Air Conditioner	< 18,000	10 (33ft)	5 (16ft)
	≥ 18,000 and < 21,000	15 (49ft)	8(26ft)
	≥ 21,000 and < 35,000	20 (66ft)	10(33ft)
	≥ 35,000 and < 41,000	25 (82ft)	10 (33ft)
R410A, R32 Fixed-speed Split Air Conditioner	< 18,000	20 (66ft)	8(26ft)
	≥ 18,000 and < 36,000	25 (82ft)	10(33ft)
	≥ 36,000 and < 60,000	30 (98.5ft)	15 (49ft)

### Connection Instructions – Refrigerant Piping

#### Step 1: Cut pipes

When preparing refrigerant pipes, take extra care to cut and flare them properly. This will ensure efficient operation and minimize the need for future maintenance.

- Measure the distance between the indoor and outdoor units.
- Using a pipe cutter, cut the pipe a little longer than the measured distance.
- Make sure that the pipe is cut at a perfect 90° angle.

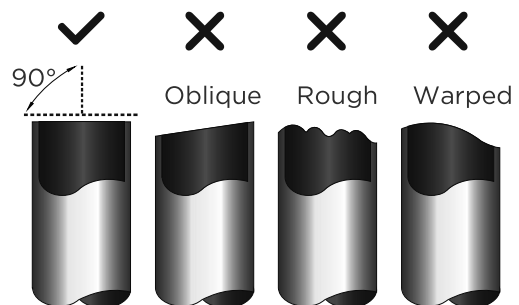

### ⊘ DO NOT DEFORM PIPE WHILE CUTTING

Be extra careful not to damage, dent, or deform the pipe while cutting. This will drastically reduce the heating efficiency of the unit.

**CAUTION**

MUST BE CHECK OVER THE END OF THE PIPE FOR CRACKS AND EVEN FLARING. ENSURE THE PIPE IS SEALED.

**Step 2: Remove burrs**

Burrs can affect the air-tight seal of refrigerant piping connection. They must be completely removed.

- Hold the pipe at a downward angle to prevent burrs from falling into the pipe.
- Using a reamer or deburring tool, remove all burrs from the cut section of the pipe.

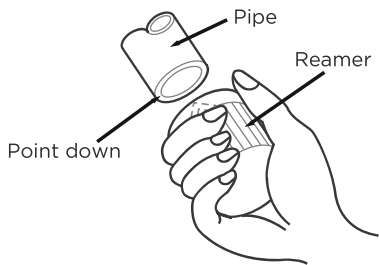

**Step 3: Flare pipe ends**

Proper flaring is essential to achieve an airtight seal.

- After removing burrs from cut pipe, seal the ends with PVC tape to prevent foreign materials from entering the pipe.
- Sheath the pipe with insulating material.
- Place flare nuts on both ends of pipe. Make sure they are facing in the right direction, because you can't put them on or change their direction after flaring.

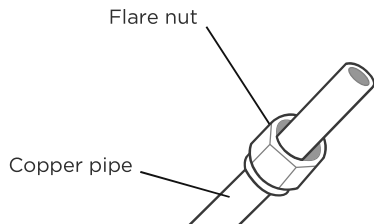

- Remove PVC tape from ends of pipe when ready to perform flaring work.
- Clamp flare form on the end of the pipe. The end of the pipe must extend beyond the edge of the flare form in accordance with the dimensions shown in the table below.

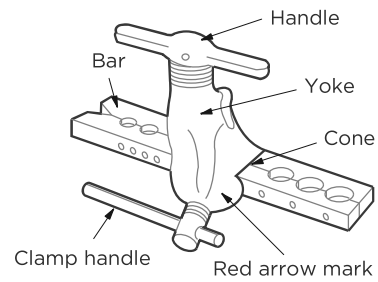

**PIPING EXTENSION BEYOND FLARE FORM**

Outer Diameter of Pipe (mm)	A (mm)	
	Min.	Max.
Ø 6.35 (Ø 1/4")	0.7 (0.0275")	1.3 (0.05")
Ø 9.52 (Ø 3/8")	1.0 (0.04")	1.6 (0.063")
Ø12.7 (Ø 1/2")	1.0 (0.04")	1.8 (0.07")
Ø 16 (Ø 5/8")	2.0 (0.078")	2.2 (0.086")
Ø 19 (Ø 3/4")	2.0 (0.078")	2.4 (0.094")

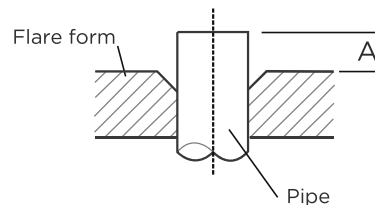

- Place flaring tool onto the form.
- Turn the handle of the flaring tool clockwise until the pipe is fully flared.
- Remove the flaring tool and flare form, then inspect the end of the pipe for cracks and even flaring.

## 2 Refer to Torque Requirement to connect pipes

### ⚠ CAUTION

WHEN CONNECTING REFRIGERANT PIPES, BE CAREFUL NOT TO USE EXCESSIVE TORQUE OR TO DEFORM THE PIPING IN ANY WAY. YOU SHOULD FIRST CONNECT THE LOW-PRESSURE PIPE, THEN THE HIGH-PRESSURE PIPE.

#### MINIMUM BEND RADIUS

When bending connective refrigerant piping, the minimum bending radius is 10cm.

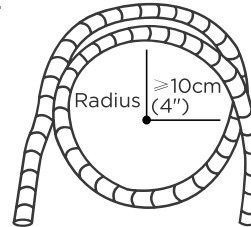

### Instructions for Connecting Piping to Indoor Unit

#### Step 1:

- Align the center of the two pipes that you will connect.

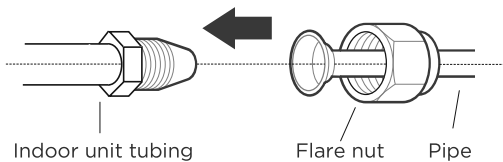

#### Step 2:

- Tighten the flare nut as tightly as possible by hand.
- Using a spanner, grip the nut on the unit tubing.
- While firmly gripping the nut on the unit tubing, use a torque wrench to tighten the flare nut according to the torque values in the Torque Requirements table below. Loosen the flaring nut slightly, then tighten again.

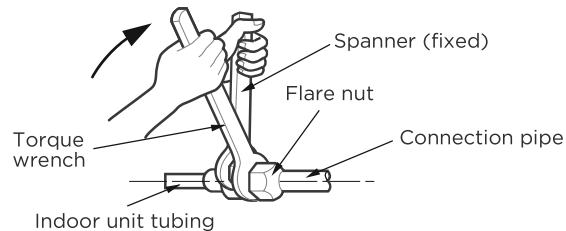

### TORQUE REQUIREMENTS

Outer Diameter of Pipe(mm)	Tightening Torque(N·m)	Flare dimension(B)(mm)	Flare shape
∅ 6.35 (∅ 1/4")	18-20(180-200kgf.cm)	8.4-8.7 (0.33-0.34")	
∅ 9.52 (∅ 3/8")	32-39(320-390kgf.cm)	13.2-13.5 (0.52-0.53")	
∅ 12.7 (∅ 1/2")	49-59(490-590kgf.cm)	16.2-16.5 (0.64-0.65")	
∅ 16 (∅ 5/8")	57-71(570-710kgf.cm)	19.2-19.7 (0.76-0.78")	
∅ 19 (∅ 3/4")	67-101(670-1010kgf.cm)	23.2-23.7 (0.91-0.93")	

### ⊘ DO NOT USE EXCESSIVE TORQUE

Excessive force can break the nut or damage the refrigerant piping. You must not exceed torque requirements shown in the table above.

### 3 Connecting Piping to Outdoor Unit

#### NOTE

This section still needs to be operated according to the **TORQUE REQUIREMENTS** chart on the previous page.

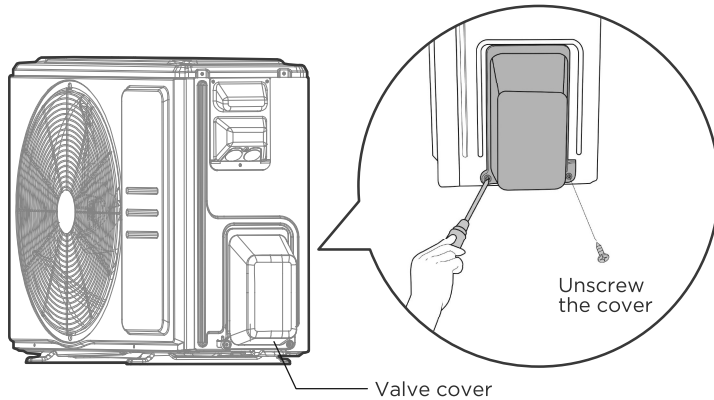

#### Step 1:

- Unscrew the cover from the packed valve on the side of the outdoor unit.

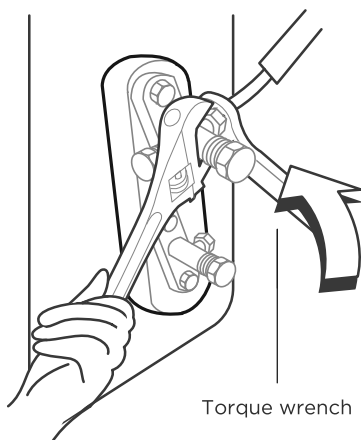

#### Step 2:

- Remove protective caps from ends of valves.
- Align flared pipe end with each valve, and tighten the flare nut as tightly as possible by hand.
- Using a spanner, grip the body of the valve. **Do not** grip the nut that seals the service valve.

 USE SPANNER TO GRIP MAIN BODY OF VALVE

Torque from tightening the flare nut can snap off other parts of valve.

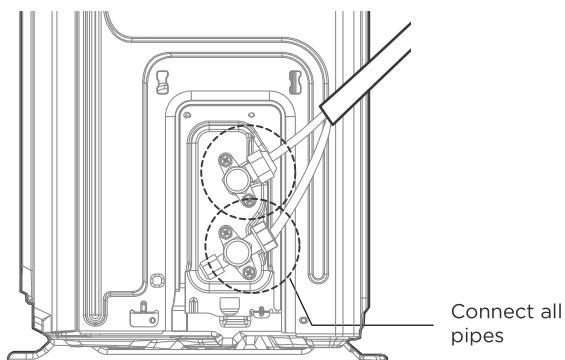

#### Step 3:

- While firmly gripping the body of the valve, use a torque wrench to tighten the flare nut according to the correct torque values.
- Loosen the flaring nut slightly, then tighten again.
- Repeat Steps 1 to 3 for the remaining pipe.

## Air Evacuation



### NOTE : PREPARATIONS AND PRECAUTIONS

Air and foreign matter in the refrigerant circuit can cause abnormal rises in pressure, which can damage the air conditioner, reduce its efficiency, and cause injury. Use a vacuum pump and manifold gauge to evacuate the refrigerant circuit, removing any non-condensable gas and moisture from the system. Evacuation should be performed upon initial installation and when unit is relocated.



### BEFORE PERFORMING EVACUATION

- ✓ Make sure the connective pipes between the indoor and outdoor units are connected properly.
- ✓ Check to make sure all wiring is connected properly.

### Evacuation Instructions

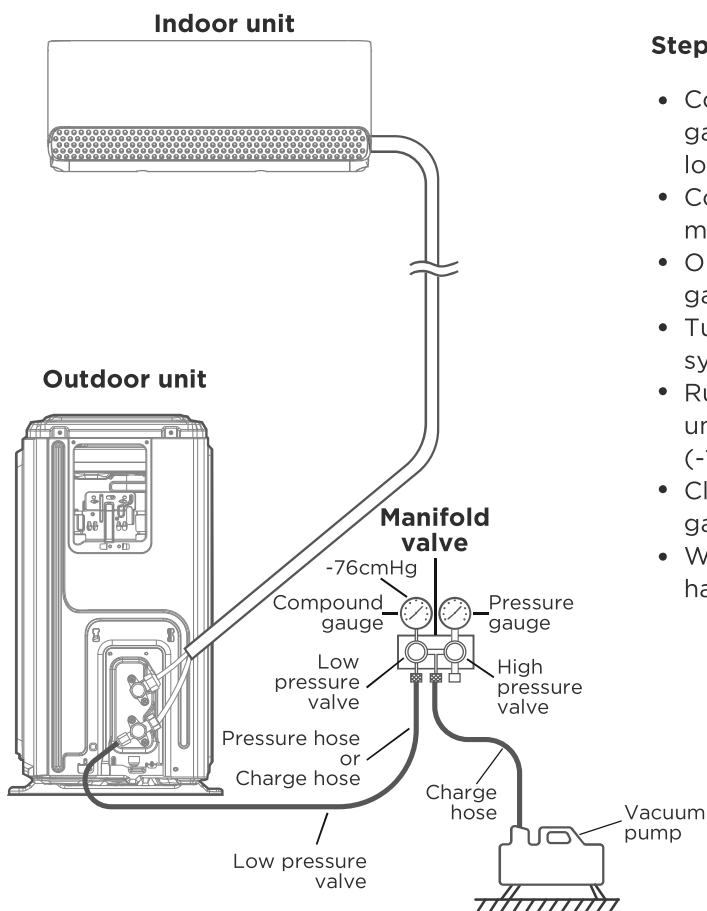

#### Step 1:

- Connect the charge hose of the manifold gauge to service port on the outdoor unit's low pressure valve.
- Connect another charge hose from the manifold gauge to the vacuum pump.
- Open the Low Pressure side of the manifold gauge. Keep the High Pressure side closed.
- Turn on the vacuum pump to evacuate the system.
- Run the vacuum for at least 15 minutes, or until the Compound Meter reads -76cmHG (-10 Pa).
- Close the Low Pressure side of the manifold gauge, and turn off the vacuum pump.
- Wait for 5 minutes, then check that there has been no change in system pressure.

## Step 2:

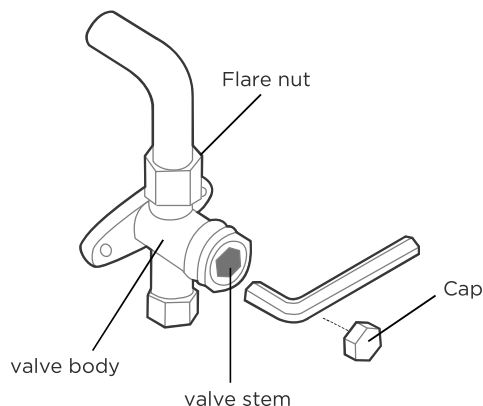

- If there is a change in system pressure, refer to Gas Leak Check section for information on how to check for leaks. If there is no change in system pressure, unscrew the cap from the packed valve (high pressure valve). Insert hexagonal wrench into the packed valve (high pressure valve) and open the valve by turning the wrench in a 1/4 counterclockwise turn. Listen for gas to exit the system, then close the valve after 5 seconds.
- Watch the Pressure Gauge for one minute to make sure that there is no change in pressure. The Pressure Gauge should read slightly higher than atmospheric pressure.
- Remove the charge hose from the service port.
- Using hexagonal wrench, fully open both the high pressure and low pressure valves.
- Tighten valve caps on all three valves (service port, high pressure, low pressure) by hand. You may tighten it further using a torque wrench if needed.

### ! OPEN VALVE STEMS GENTLY

When opening valve stems, turn the hexagonal wrench until it hits against the stopper. Do not try to force the valve to open further.

### NOTE ON ADDING REFRIGERANT

Some systems require additional charging depending on pipe lengths. The standard pipe length varies according to local regulations. For example, in North America, the standard pipe length is 7.5m (25'). In other areas, the standard pipe length is 5m (16'). The refrigerant should be charged from the service port on the outdoor unit's low pressure valve. The additional refrigerant to be charged can be calculated using the following formula:

### ADDITIONAL REFRIGERANT PER PIPE LENGTH

Connective Pipe Length (m)	Air Purging Method	Additional Refrigerant	
≤ Standard pipe length	Vacuum Pump	N/A	
> Standard pipe length	Vacuum Pump	Liquid Side: Ø 6.35 (1/4") R410A: (Pipe length - standard length) x 15g/m (Pipe length - standard length) x 0.16oz/ft R32: (Pipe length - standard length) x 12g/m (Pipe length - standard length) x 0.13oz/ft R22: (Pipe length - standard length) x 20g/m (Pipe length - standard length) x 0.21oz/ft	Liquid Side: Ø 9.52 (3/8") R410A: (Pipe length - standard length) x 30g/m (Pipe length - standard length) x 0.32oz/ft R32: (Pipe length - standard length) x 24g/m (Pipe length - standard length) x 0.26oz/ft R22: (Pipe length - standard length) x 40g/m (Pipe length - standard length) x 0.42oz/ft

⊘ DO NOT MIX REFRIGERANT TYPES.

## Electrical And Gas Leak Checks



### WARNING - RISK OF ELECTRIC SHOCK

ALL WIRING MUST COMPLY WITH LOCAL AND NATIONAL ELECTRICAL CODES, AND MUST BE INSTALLED BY A LICENSED ELECTRICIAN.



### BEFORE TEST RUN

Only perform test run after you have completed the following steps:

- Electrical Safety Checks – Confirm that the unit's electrical system is safe and operating properly
- Gas Leak Checks – Check all flare nut connections and confirm that the system is not leaking
- Confirm that gas and liquid (high and low pressure) valves are fully open

### Electrical Safety Checks

After installation, confirm that all electrical wiring is installed in accordance with local and national regulations, and according to the Installation Manual.

### BEFORE TEST RUN

#### Check Grounding Work

Measure grounding resistance by visual detection and with grounding resistance tester.

### DURING TEST RUN

#### Check for Electrical Leakage

During the **Test Run**, use an electroprobe and multimeter to perform a comprehensive electrical leakage test.

If electrical leakage is detected, turn off the unit immediately and call a licensed electrician to find and resolve the cause of the leakage.

**Note:** This may not be required for some locations in North America.

### Gas Leak Checks

There are two different methods to check for gas leaks.

#### Soap and Water Method

Using a soft brush, apply soapy water or liquid detergent to all pipe connection points on the indoor unit and outdoor unit. The presence of bubbles indicates a leak.

#### Leak Detector Method

If using leak detector, refer to the device's operation manual for proper usage instructions.

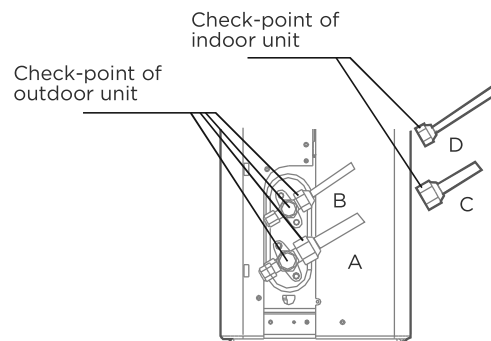

- A: Low pressure stop valve
- B: High pressure stop valve
- C & D: Indoor unit flare nuts

### AFTER PERFORMING GAS LEAK CHECKS

After confirming that all pipe connection points DO NOT leak, replace the valve cover on the outside unit.



# Test Run

## Test Run Instructions

You should perform the **Test Run** for at least 30 minutes.

- Connect power to the unit.
- Press the **ON/OFF** button on the remote controller to turn it on.
- Press the **MODE** button to scroll through the following functions, one at a time:
  - COOL-Select lowest possible temperature
  - HEAT-Select highest possible temperature
- Let each function run for 5 minutes, and perform the following checks:

List of Checks to Perform	PASS/FAIL	
No electrical leakage		
Unit is properly grounded		
All electrical terminals properly covered		
Indoor and outdoor units are solidly installed		
All pipe connection points do not leak	Outdoor (2):	Indoor (2):
Water drains properly from drain hose		
All piping is properly insulated		
Unit performs COOL function properly		
Unit performs HEAT function properly		
Indoor unit louvers rotate properly		
Indoor unit responds to remote controller		

## DOUBLE-CHECK PIPE CONNECTIONS

During operation, the pressure of the refrigerant circuit will increase. This may reveal leaks that were not present during your initial leak check. Take time during the Test Run to double-check that all refrigerant pipe connection points do not have leaks. Refer to **Gas Leak Check** section for instructions.

- After the Test Run is successfully completed, and you confirm that all checks points in List of Checks to Perform have PASSED, do the following:
  - a. Using remote control, return unit to normal operating temperature.
  - b. Using insulation tape, wrap the indoor refrigerant pipe connections that you left uncovered during the indoor unit installation process.

## IF AMBIENT TEMPERATURE IS BELOW 16°C(60°F)

You can't use the remote controller to turn on the COOL function when the ambient temperature is below 16°C/62°F. In this instance, you can use the **MANUAL CONTROL** button to test the COOL function.

- Lift the front panel of the indoor unit, and raise it until it clicks in place.
- The **MANUAL CONTROL** button is located on the right-hand side of the unit. Press it 2 times to select the COOL function.
- Perform Test Run as normal.

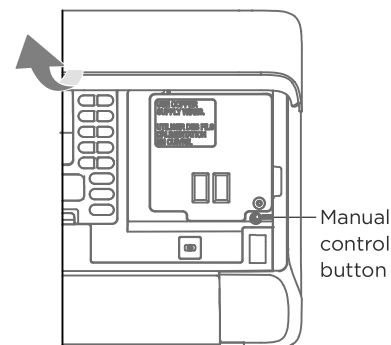

## Packing And Unpacking The Unit

### Instructions for packing and unpacking the unit:

#### Unpacking:

##### Indoor unit:

1. Cut the sealing tape on the carton with a knife, one cut on the left, one cut in the middle and one cut on the right.
2. Use the vice to take out the sealing nails on the top of the carton.
3. Open the carton.
4. Take out the middle support plate if it is included.
5. Take out the accessory package, and take out the connecting wire if it is included.
6. Lift the machine out of the carton and lay it flat.
7. Remove the left and right package foam or the upper and lower packaging foam, untie the packaging bag.

##### Outdoor Unit

1. Cut the packing belt.
2. Take the unit out of the carton.
3. Remove the foam from the unit.
4. Remove the packaging bag from the unit.

#### Packing:

##### Indoor unit:

1. Put the indoor unit into the packing bag.
2. Attach the left and right package foam or the upper and lower packaging foam to the unit.
3. Put the unit into the carton, then put accessory package in.
4. Close the carton and seal it with the tape.
5. Using the packing belt if necessary.

##### Outdoor unit:

1. Put the outdoor unit into the packing bag.
2. Put the bottom foam into the box.
3. Put the unit into the carton, then put the upper packaging foam on the unit.
4. Close the carton and seal it with the tape.
5. Using the packing belt if necessary.

**NOTE:** Please keep all packaging items if you may need in the future.

# OPERATION INSTRUCTIONS

## NOTE

- Different models have different front panel and display window. Not all the indicators describing below are available for the air conditioner you purchased. Please check the indoor display window of the unit you purchased.
- Illustrations in this manual are for explanatory purposes. The actual shape of your indoor unit may be slightly different. The actual shape shall prevail.

## Indoor Unit Display

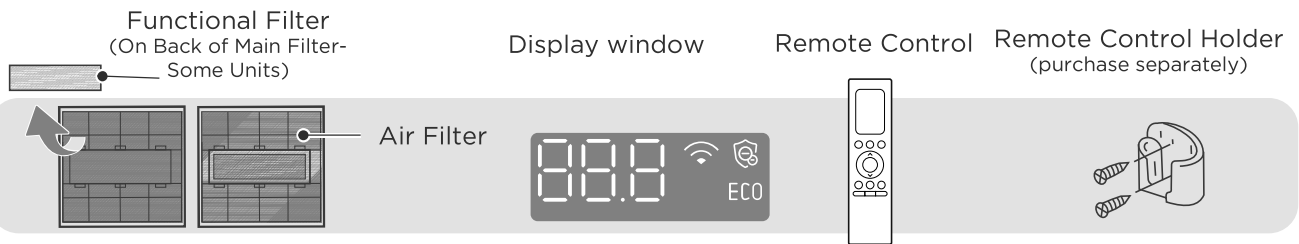
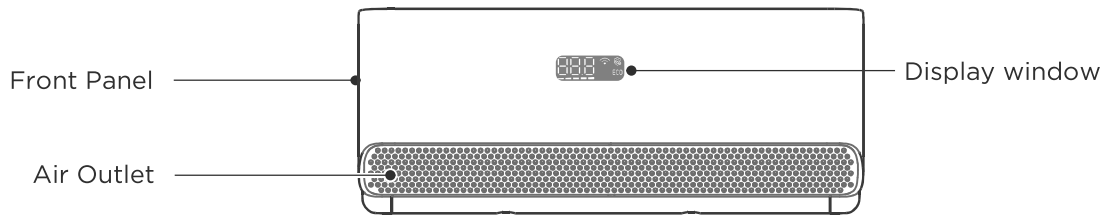

Display Code	Display Code Meanings
88.8	• Displays temperature, operation feature and Error codes.
📶	• When Wireless Control feature is activated.
🛡️	• When Air magic or UV lamp(if any) feature is activated.
ECO	• When ECO feature is activated.
ON (for 3s when)	• TIMER ON is set (if the unit is OFF, "ON" remains on when TIMER ON is set ). • UV lamp, Fresh, Brezzeless, SWING, TURBO, or SILENCE features is turned on.
OF (for 3s when)	• TIMER OFF is set. • UV lamp, Fresh, Brezzeless, SWING, TURBO, or SILENCE features is turned off.
dF	• When defrosting(cooling & heating units).
CL	• When active clean function is turned on.
FP	• When 8°C(46°F) heating mode is turned on.

## Operating Temperature

When your air conditioner is used outside of the following temperature ranges, certain safety protection features may activate and cause the unit to disable.

### Inverter Split Type

	COOL Mode	HEAT Mode	DRY Mode
Room Temp.	16°C-32°C(60°F-90°F)	0°C-30°C(32°F-86°F)	10°C-32°C(50°F-90°F)
Outdoor Temp.	0°C-50°C(32°F-122°F)		
	-15°C-50°C(5°F-122°F) For models with low temp. cooling systems.	-15°C-24°C(5°F-75°F)	0°C-50°C(32°F-122°F)
	-15°C-50°C(5°F-122°F) For special tropical models	-15°C-24°C(5°F-75°F)	0°C-52°C(32°F-126°F) For special tropical models

#### FOR OUTDOOR UNITS WITH AUXILIARY ELECTRIC HEATER

When outside temperature is below 0°C (32°F), we strongly recommend keeping the unit plugged in at all time to ensure smooth ongoing performance.

### Fixed-speed Type

	COOL Mode	HEAT Mode	DRY Mode
Room Temp.	16°C-32°C (60°F-90°F)	0°C-30°C (32°F-86°F)	10°C-32°C(50°F-90°F)
Outdoor Temp.	18°C-43°C (64°F-109°F)		11°C-43°C (52°F-109°F)
	-7°C-43°C (19°F-109°F) For models with low-temp cooling systems	-7°C-24°C(19°F-75°F)	18°C-43°C (64°F-109°F)
	18°C-52°C (64°F-126°F) For special tropical models	-15°C-24°C(5°F-75°F)	18°C-52°C (64°F-126°F) For special tropical models

**NOTE:** Room relative humidity less than 80%. If the air conditioner operates in excess of this figure, the surface of the air conditioner may attract condensation. Please sets the vertical air flow louver to its maximum angle (vertically to the floor), and set HIGH fan mode.

## To further optimize the performance of your unit, do the following:

- Keep doors and windows closed.
- Limit energy usage by using TIMER ON and TIMER OFF functions.
- Do not block air inlets or outlets.
- Regularly inspect and clean air filters.

## More features

- **Auto-Restart**  
If the unit loses power, it will automatically restart with the prior settings once power has been restored.
- **Anti-mildew(some units)**  
When turning off the unit from COOL, AUTO (COOL), or DRY modes, the air conditioner will continue operate at very low power to dry up condensed water and prevent mildew growth.
- **Wireless Control (Model dependent)**  
Wireless control allows you to control your air conditioner using your mobile phone and a wireless connection.  
For the USB device access, replacement, maintenance operations must be carried out by professional staff.
- **Active Clean function(some units)**
  - The Active Clean Technology washes away dust when it adheres to the heat exchanger by automatically freezing and then rapidly thawing the frost. A “pi-pi” sound will be heard. The Active clean operation is used to produce more condensed water to improve the cleaning effect, and the cold air will blow out. After cleaning, the internal wind wheel then keeps operating with hot air to blow-dry the evaporator, thus keeping the inside clean.
  - When this function is turned on, the indoor unit display window appears “CL ” , after 20 to 130 minutes, the unit will turn off automatically and cancel Active Clean function.
  - For some units, the system will start high-temperature cleaning process, and the temperature of air outlet is very high. Please keep away from it. And this would lead to the rising of the room temperature .
- **Louver Angle Memory**  
When turning on your unit, the louver will automatically resume its former angle.
- **Air Magic+ function(some units)**  
Under the effect of electric field generated by outer double-tube emitter, millions of negative ions are formed as Super Negative Ion Shockwave to eradicate bacteria and viruses in wider extent.
- **Coolflash function**  
Cool Flash technology can drive your whole room to the instant cool. With large air volume and long airflow, the temperature of the whole room can be reduced in a short time.
- **Heatflash function**  
With fast and strong heating airflow, the Heat Flash technology can warm up your whole room in a short time.
- **Refrigerant Leakage Detection**  
The indoor unit will automatically display “ELOC” when it detects refrigerant leakage.
- **UV-C lamp function(some units)**  
When the UV lamp function is initiated, the UV lamp emit UV-C radiation to help to purify the air inside.
- **Breezeless function**
  - The revolutionary double deflectors can bend, veer and soften the airflow to provide multiple levels of softness as you demand.
  - Enjoy the cozy coolness with breeze billowing away from you, with mild breeze, or eventually without a noticeable breeze.
  - The deflector consist of thousands of mini-holes can transform the strong airflow into thousands of tiny strings of air that gives you softest touch of cooling.

**Breezeless Operation**

The air conditioner will adjust the louver angle and fan speed automatically on the basis of room temperature and humidity variable. There are four different operation state, See Fig. 1, Fig. 2, Fig. 3, Fig. 4 .

Breeze billowing away

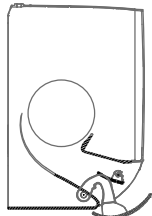

Fig. 1

Mild breeze

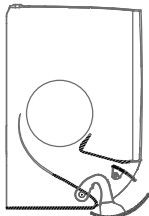

Fig. 2

Breezeless

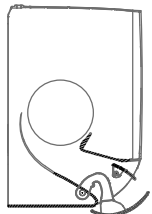

Fig. 3

Breezeless

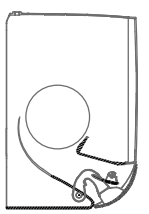

Fig. 4

NOTE: For the rooms with large heat load or the outdoor temperature is too high, you'd better not choose breezeless operation, this may result in uncomfortable feeling.

**Sleep Operation**

The SLEEP function is used to decrease energy use while you sleep (and don't need the same temperature settings to stay comfortable).

Press the **SLEEP** button on remote control when in COOL mode, the unit will increase the temperature by 1°C (2°F) after 1 hour, and will increase an additional 1°C (2°F) after another hour.

When in HEAT mode, the unit will decrease the temperature by 1°C (2°F) after 1 hour, and will decrease an additional 1°C (2°F) after another hour.

The sleep feature will stop after 8 hours and the system will keep running with final situation.

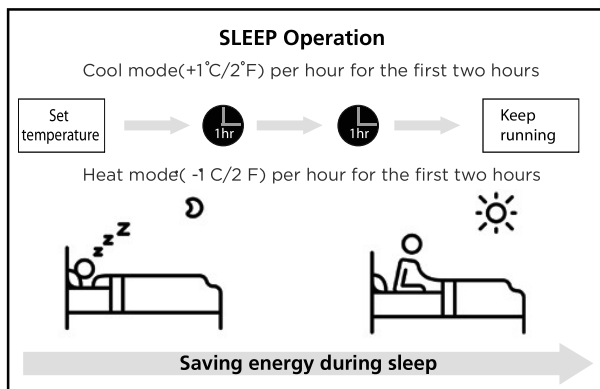

**Setting Angle of Air Flow**

**NOTE : Setting angle of air flow(Remote control)**

While the unit is on, use the SWING button on remote control to set the direction (vertical/horizontal angle) of airflow. Please refer to the Remote Control operation for details.

**NOTE ON LOUVER ANGLES**

- Do not set louver at too vertical an angle for long periods of time When using COOL or DRY mode. It would be condense the water on the louver blade, which will drop on your floor or furnishings.

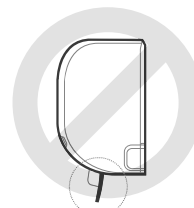

- Setting the louver at too small an angle when using COOL or HEAT mode, can reduce the performance of the AC due to restricted air flow.

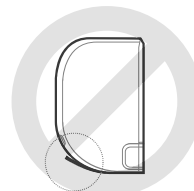

- According to the relative standards requirement, please sets the vertical air flow louver to its maximum angle under heating capacity test.

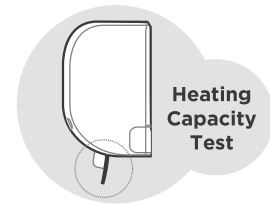

## NOTE

Do not move louver by hand. This will cause the louver to become out of sync. If this occurs, turn off the unit and unplug it for a few seconds, then restart the unit. This will reset the louver.

## CAUTION

Do not put your fingers in or near the blower and suction side of the unit. The high-speed fan inside the unit may cause injury.

## Manual Operation(without remote)

### CAUTION : For product use

The manual button is intended for testing purposes and emergency operation only. Please do not use this function unless the remote control is lost and it is absolutely necessary. To restore regular operation, use the remote control to activate the unit. Unit must be turned off before manua operation.

## To operate your unit manually:

- Open the front panel of the indoor unit.
- Locate the **MANUAL CONTROL button** on the right-hand side of the unit.
- Press the **MANUAL CONTROL button** one time to activate FORCED AUTO mode.
- Press the **MANUAL CONTROL button** again to activate FORCED COOLING mode.
- Press the **MANUAL CONTROL button** a third time to turn the unit off.
- Close the front panel.

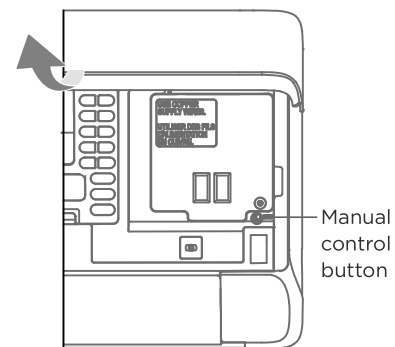

# Remote Control Operation

## Quick Start Guide

1 FIT BATTERIES

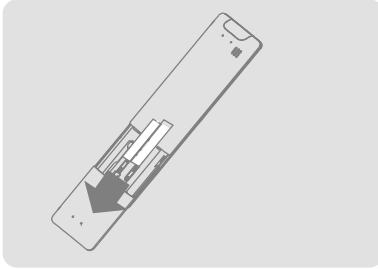

2 SELECT MODE

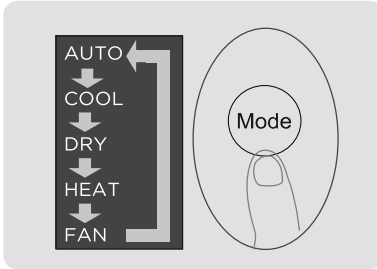

3 SELECT TEMPERATURE

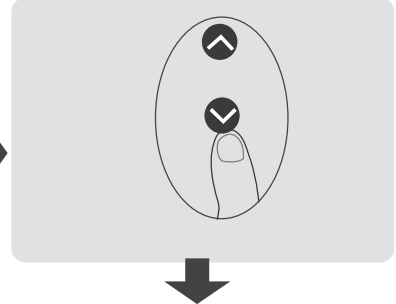

6 PRESS POWER BUTTON

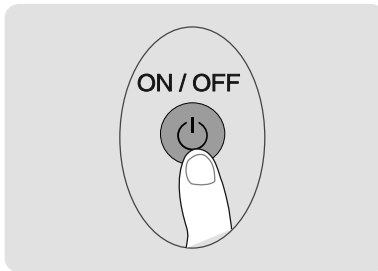

5 POINT REMOTE TOWARD UNIT

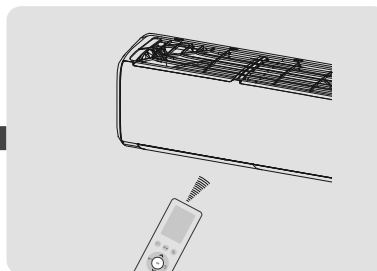

4 SELECT FAN SPEED

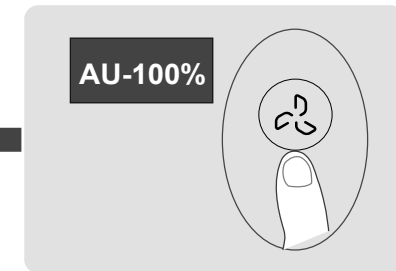

### NOT SURE WHAT A FUNCTION DOES?

Refer to the How to Use Basic Functions and How to Use Advanced Functions sections of this manual for a detailed description of how to use your air conditioner.

### SPECIAL NOTE

- Button designs on your unit may differ slightly from the example shown.
- If the indoor unit does not have a particular function, pressing that function's button on the remote control will have no effect.



## Handling the Remote Controller

### Inserting and Replacing Batteries

Your air conditioning unit may come with two batteries (some units). Put the batteries in the remote control before use.

1. Slide the back cover from the remote control downward, exposing the battery compartment.
2. Insert the batteries, paying attention to match up the (+) and (-) ends of the batteries with
3. the symbols inside the battery compartment. Slide the battery cover back into place.

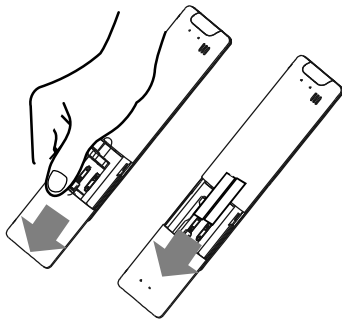

### BATTERY NOTES

For optimum product performance:

- Do not mix old and new batteries, or batteries of different types.
- Do not leave batteries in the remote control if you don't plan on using the device for more than 2 months.

### BATTERY DISPOSAL

Do not dispose of batteries as unsorted municipal waste. Refer to local laws for proper disposal of batteries.

### TIPS FOR USING REMOTE CONTROL

- The remote control must be used within 8 meters of the unit.
- The unit will beep when remote signal is received.
- Curtains, other materials and direct sunlight can interfere with the infrared signal receiver.
- Remove batteries if the remote will not be used more than 2 months.

### NOTES FOR USING REMOTE CONTROL

The device could comply with the local national regulations.

- In Canada, it should comply with CAN ICES-3(B)/NMB-3(B).
- In USA, this device complies with part 15 of the FCC Rules. Operation is subject to the following two conditions:
  - (1) This device may not cause harmful interference, and
  - (2) this device must accept any interference received, including interference that may cause undesired operation.

This equipment has been tested and found to comply with the limits for a Class B digital device, pursuant to part 15 of the FCC Rules. These limits are designed to provide reasonable protection against harmful interference in a residential installation. This equipment generates, uses and can radiate radio frequency energy and, if not installed and used in accordance with the instructions, may cause harmful interference to radio communications. However, there is no guarantee that interference will not occur in a particular installation. If this equipment does cause harmful interference to radio or television reception, which can be determined by turning the equipment off and on, the user is encouraged to try to correct the interference by one or more of the following measures:

- Reorient or relocate the receiving antenna.
- Increase the separation between the equipment and receiver.
- Connect the equipment into an outlet on a circuit different from that to which the receiver is connected.
- Consult the dealer or an experienced radio/TV technician for help.
- Changes or modifications not approved by the party responsible for compliance could void user's authority to operate the equipment.

## Buttons and Functions

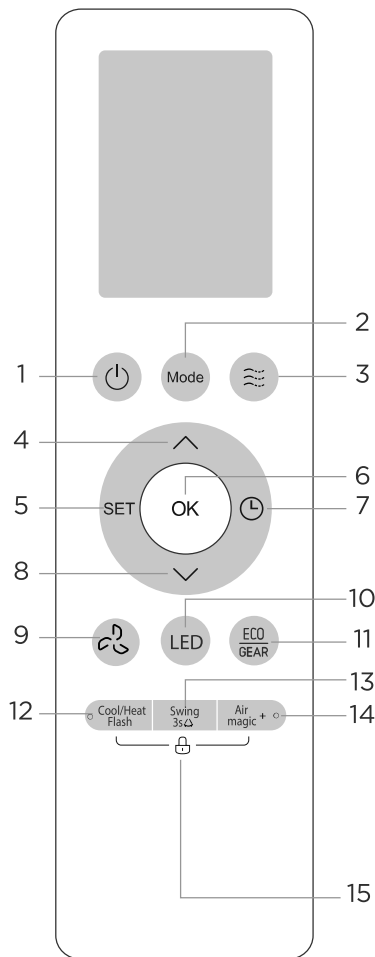

Model A

Description	
No.1	ON/OFF Turn the unit on or off.
No.2	MODE Auto > Cool > Dry > Heat > Fan <b>NOTE:</b> HEAT mode is not supported by the cooling only appliance.
No.3	BREEZE Breezeless > Breeze away > Breeze mild>Stop
No.4	TEMP. Increases temperature in 0.5°C (1°F) increments. Max. temperature is 30°C (86°F). (Press together  &  buttons at the same time for 3 seconds will alternate the temperature display between the °C & °F).
No.5	SET Active clean>Sleep > Follow Me > AP mode > Active clean
No.6	OK Used to confirm the selected functions
No.7	TEMP. Set timer to turn unit on or off
No.8	TEMP. Decreases temperature in 0.5°C (1°F) increments. Min. temperature is 16°C (60°F)
No.9	FAN SPEED AU > 20% > 40% > 60% > 80% > 100% Press the TEMP  or  button to increase/ decrease the fan speed in 1% increments.
No.10	LED Turns LED display & air conditioner buzzer on and off
No.11	ECO/GEAR ECO > GEAR(75%) > GEAR(50%) > Previous setting mode > ECO
No.12	Cool/Heat Flash Reduce(cool mode) or rise(heat mode) temperature in a short time.
No.13	SWING Starts and stops the horizontal louver movement. Hold down for 3 seconds to initiate vertical louver auto swing feature(some units).
No.14	Air magic+ Used to start/stop the Air magic and UV-C lamp (if any) function.
No.15	LOCK Press together these two buttons simultaneously for 5 seconds to lock the keyboard. Press together these two buttons for 2 seconds to unlock the keyboard.

## Buttons and Functions

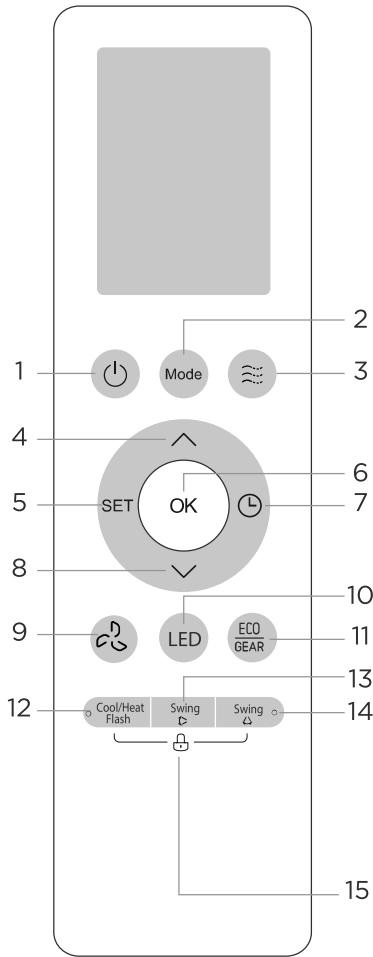

Model B

Description	
No.1	ON/OFF Turn the unit on or off.
No.2	MODE Auto > Cool > Dry > Heat > Fan <b>NOTE:</b> HEAT mode is not supported by the cooling only appliance.
No.3	BREEZE Breezeless > Breeze away > Breeze mild>Stop
No.4	TEMP. Increases temperature in 0.5°C (1°F) increments. Max. temperature is 30°C (86°F). (Press together  &  buttons at the same time for 3 seconds will alternate the temperature display between the °C & °F).
No.5	SET Active clean > Sleep > Follow Me > AP mode* > Active clean <b>[*]:</b> Model dependent
No.6	OK Used to confirm the selected functions
No.7	TEMP. Set timer to turn unit on or off
No.8	TEMP. Decreases temperature in 0.5°C (1°F) increments. Min. temperature is 16°C (60°F)
No.9	FAN SPEED AU > 20% >40% >60% > 80% > 100% Press the TEMP  or  button to increase/ decrease the fan speed in 1% increments.
No.10	LED Turns LED display & air conditioner buzzer on and off
No.11	ECO/GEAR ECO > GEAR(75%) > GEAR(50%) > Previous setting mode > ECO
No.12	Cool/Heat Flash Reduce(cool mode) or rise(heat mode) temperature in a short time.
No.13	SWING(up and down) Starts and stops the horizontal louver movement. Hold down for 2 seconds to initiate horizontal louver auto swing feature(some units).
No.14	SWING(left and right) Starts and stops the vertical louver movement.
No.15	LOCK Press together these two buttons simultaneously for 5 seconds to lock the keyboard. Press together these two buttons for 2 seconds to unlock the keyboard.

## Buttons and Functions

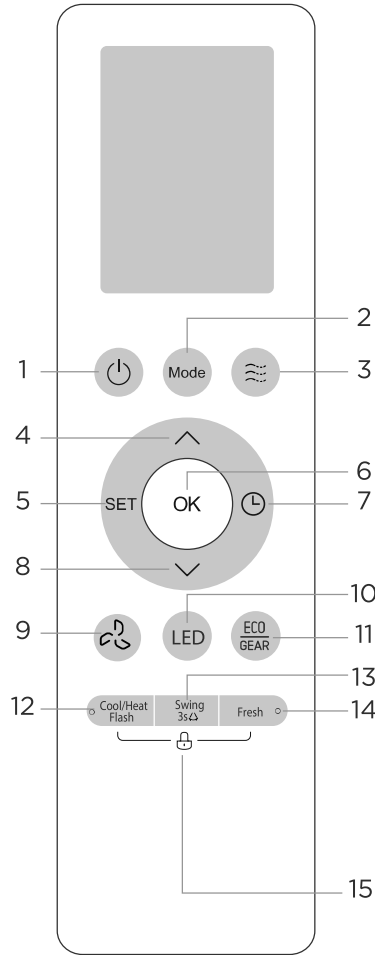

Model C

Description	
No.1	ON/OFF Turn the unit on or off.
No.2	MODE Auto > Cool > Dry > Heat > Fan <b>NOTE:</b> HEAT mode is not supported by the cooling only appliance.
No.3	BREEZE Breezeless > Breeze away > Breeze mild>Stop
No.4	TEMP. Increases temperature in 0.5°C (1°F) increments. Max. temperature is 30°C (86°F). (Press together  &  buttons at the same time for 3 seconds will alternate the temperature display between the °C & °F).
No.5	SET Active clean > Sleep > Follow Me > AP mode* > Active clean <b>[*]:</b> Model dependent
No.6	OK Used to confirm the selected functions
No.7	TEMP. Set timer to turn unit on or off
No.8	TEMP. Decreases temperature in 0.5°C (1°F) increments. Min. temperature is 16°C (60°F)
No.9	FAN SPEED AU > 20% > 40% > 60% > 80% > 100% Press the TEMP  or  button to increase/ decrease the fan speed in 1% increments.
No.10	LED Turns LED display & air conditioner buzzer on and off
No.11	ECO/GEAR ECO > GEAR(75%) > GEAR(50%) > Previous setting mode > ECO
No.12	Cool/Heat Flash Reduce(cool mode) or rise(heat mode) temperature in a short time.
No.13	SWING Starts and stops the horizontal louver movement. Hold down for 3 seconds to initiate vertical louver auto swing feature(some units).
No.14	FRESH Starts and stops the UV lamp function.
No.15	LOCK Press together these two buttons simultaneously for 5 seconds to lock the keyboard. Press together these two buttons for 2 seconds to unlock the keyboard.

## Remote Screen Indicators

Information are displayed when the remote controller is power up.

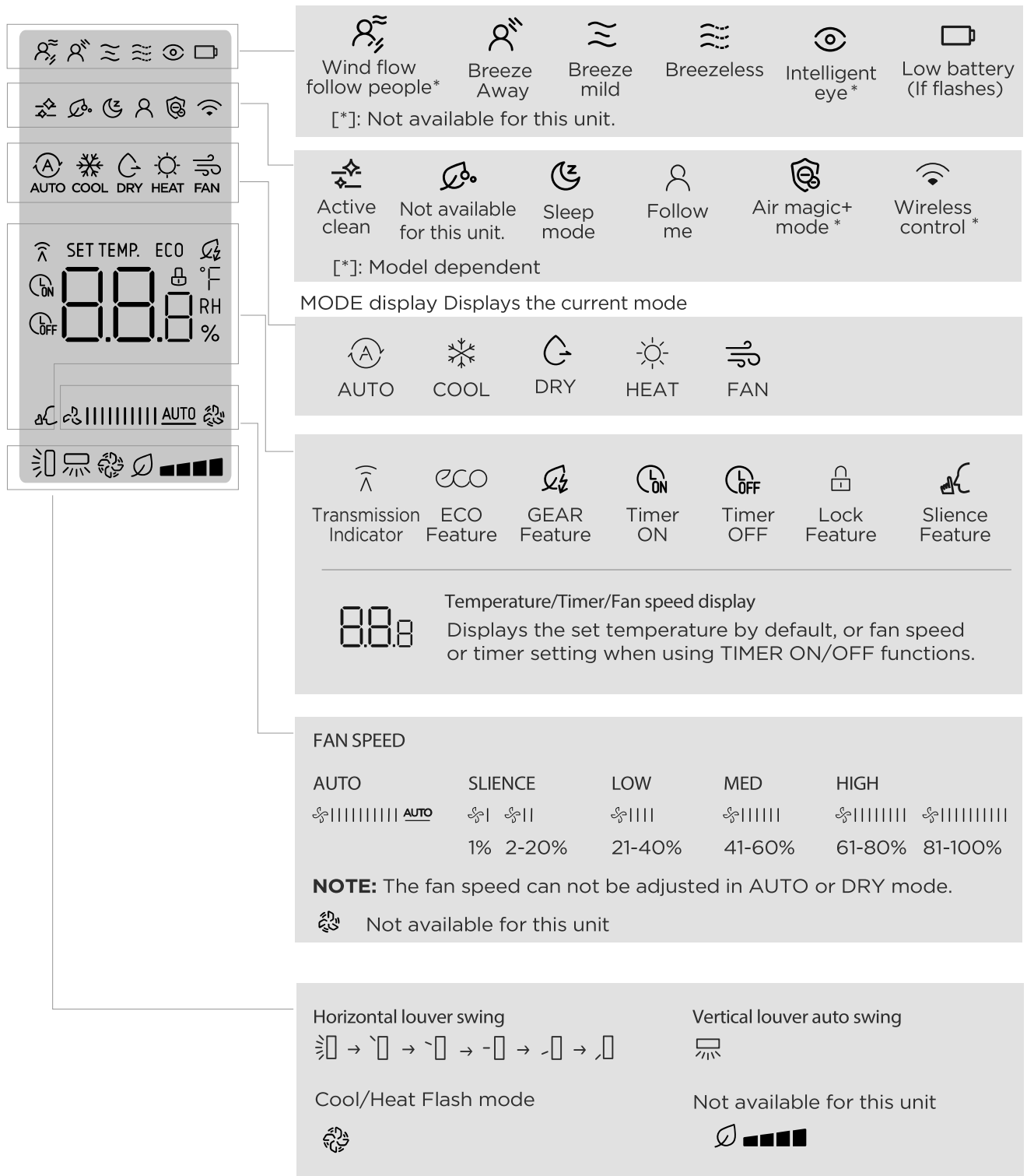

### NOTE

- All indicators shown in the figure are for the purpose of clear presentation. But during the actual operation, only the relative function signs are shown on the display window.

## How to Use Basic Functions

### NOTE

Before operation, please ensure the unit is plugged in and power is available.

#### AUTO Mode

Select AUTO mode

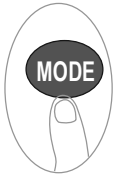

Set your desired temperature

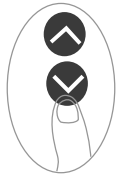

Turn on the air conditioner



#### NOTE:

1. In AUTO mode, the unit will automatically select the COOL, FAN, or HEAT function based on the set temperature.
2. In AUTO mode, fan speed can not be set.

#### COOL or HEAT Mode

Select COOL/HEAT mode

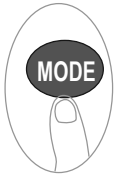

Set the temperature



Set the fan speed



Turn on the air conditioner



#### DRY Mode

Select DRY mode

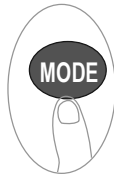

Set your desired temperature



Turn on the air conditioner



**NOTE:** In DRY mode, fan speed can not be set since it has already been automatically controlled.

#### FAN Mode

Select FAN mode

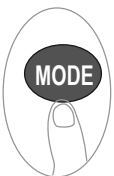

Set the fan speed



Turn on the air conditioner



**NOTE:** In FAN mode, you can't set the temperature. As a result, no temperature displays in remote screen.

## Setting the TIMER

**TIMER ON/OFF** - Set the amount of time after which the unit will automatically turn on/off.

### TIMER ON setting

Press TIMER button to initiate the ON time sequence.



Press Temp. up or down button for multiple times to set the desired time to turn on the unit.

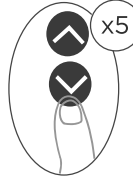

Point remote to unit and wait 1sec, the TIMER ON will be activated.



### TIMER OFF setting

Press TIMER button to initiate the OFF time sequence.



Press Temp. up or down button for multiple times to set the desired time to turn off the unit.

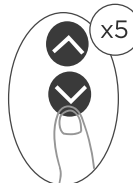

Point remote to unit and wait 1sec, the TIMER OFF will be activated.



### NOTE:

1. When setting the TIMER ON or TIMER OFF, the time will increase by 30 minutes increments with each press, up to 10 hours. After 10 hours and up to 24, it will increase in 1 hour increments. (For example, press 5 times to get 2.5h, and press 10 times to get 5h,) The timer will revert to 0.0 after 24.
2. Cancel either function by setting its timer to 0.0h.

### TIMER ON & OFF setting(example)

Keep in mind that the time periods you set for both functions refer to hours after the current time.

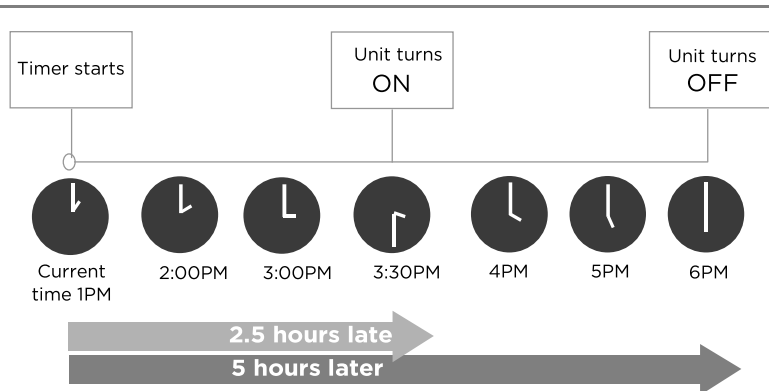
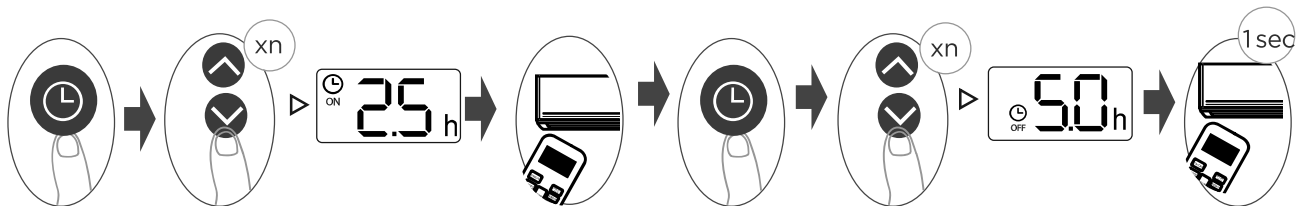

Example: If current timer is 1:00PM, to set the timer as above steps, the unit will turn on 2.5h later (3:30PM) and turn off at 6:00PM.

## How to Use Advanced Functions

### Swing function

Press Swing button

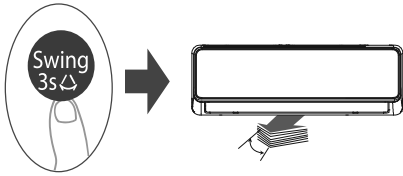

The horizontal louver will swing up and down automatically when pressing Swing button.

Set airflow direction

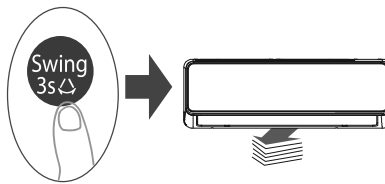

If continue to press the SWING button, five different airflow directions can be set. The louver can be move at a certain range each time you press the button. Press the button until the direction you prefer is reached.

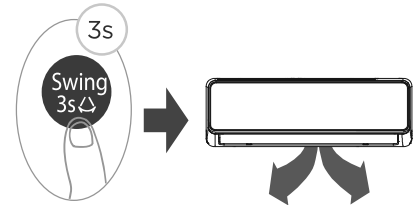

Keep pressing this button more than 3 seconds, the vertical louver swing function is activated. (Model dependent)

Press Swing button

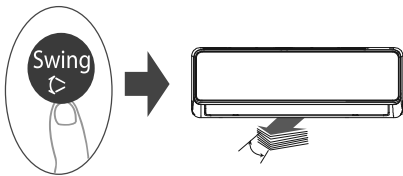

The horizontal louver will swing up and down automatically when pressing Swing button.

Set airflow direction

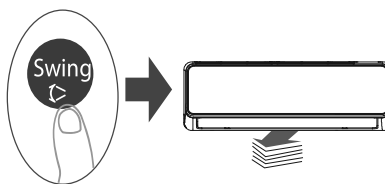

If continue to press the SWING button, five different airflow directions can be set. The louver can be move at a certain range each time you press the button. Press the button until the direction you prefer is reached.

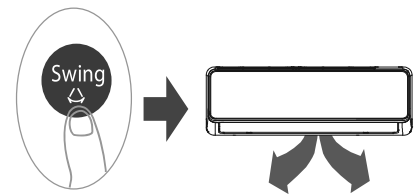

Press this button , the vertical louver swing function is activated.

### LED DISPLAY

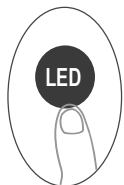

Press this button to turn on and turn off the display on the indoor unit.

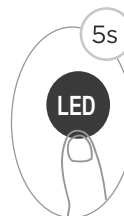

Press this button more than 5 seconds(some units)

Keep pressing this button more than 5 seconds, the indoor unit will display the actual room temperature. Press more than 5 seconds again will revert back to display the setting temperature.



## Cool/Heat Flash Function

Press this button

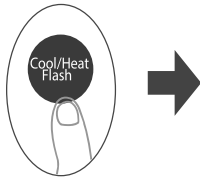

When you press this button in COOL mode, the Cool Flash technology can drive your whole room to the instant cool. With large air volume and long airflow, the temperature of the whole room can be reduced in a short time.

When you press this button in HEAT mode, with fast and strong heating airflow, the Heat Flash technology can warm up your whole room in a short time.

## ECO/GEAR function



Press this button to enter the energy efficient mode in a sequence of following:  
ECO → GEAR(75%) → GEAR(50%) → Previous setting mode → ECO.....  
Note: This function is only available under COOL mode.

### ECO operation:

Under cooling mode, press this button, the remote controller will adjust the temperature automatically to 24°C/75°F, fan speed of Auto to save energy (only when the set temperature is less than 24°C/75°F). If the set temperature is above 24°C/75°F, press the ECO button, the fan speed will change to Auto, the set temperature will remain unchanged.

**NOTE:** Pressing the ECO button, or modifying the mode or adjusting the set temperature to less than 24°C/75°F will stop ECO operation. Under ECO operation, the set temperature should be 24°C/75°F or above, it may result in insufficient cooling. If you feel uncomfortable, just press the ECO button again to stop it.

### GEAR operation:

Press the ECO/GEAR button to enter the GEAR operation as following:  
75%(up to 75% electrical energy consumption) → 50%(up to 50% electrical energy consumption) → Previous setting mode.

Under GEAR operation, the display on the remote controller will alternate between electrical energy consumption and set temperature.

## Silence function

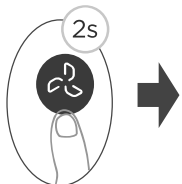

Keep pressing Fan button for more than 2 seconds to activate/disable Silence function.

Due to low frequency operation of compressor, it may result in insufficient cooling and heating capacity. Press ON/OFF, Mode, Sleep, Boost or Clean button while operating will cancel silence function.

## FP function

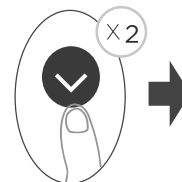



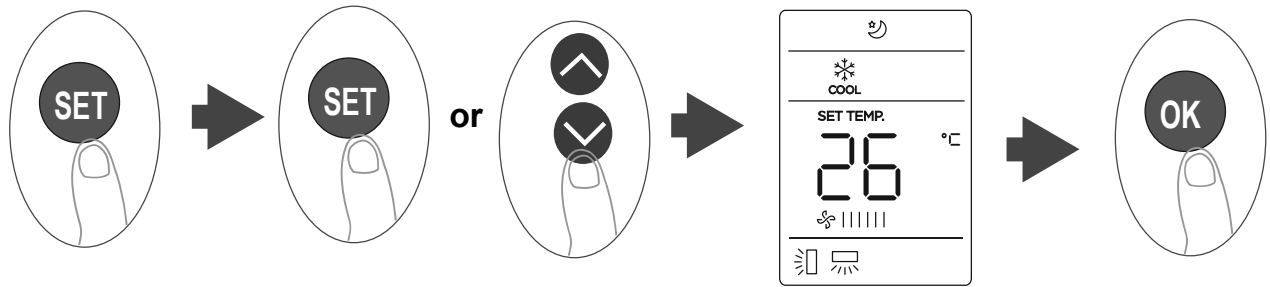

Press this button 2 times during one second under HEAT Mode and setting temperature of 16°C/60°F to activate the FP function.

The unit will operate at high fan speed (while compressor on) with temperature automatically set to 8°C/46°F.

## SET function



- Press the SET button to enter the function setting, then press SET button or TEMP  $\checkmark$  or TEMP  $\wedge$  button to select the desired function. The selected symbol will flash on the display area, press the OK button to confirm.
- To cancel the selected function, just perform the same procedures as above.
- Press the SET button to scroll through operation functions as follows:  
Active clean(  )  $\rightarrow$  Sleep(  )  $\rightarrow$  Follow Me(  )  $\rightarrow$  AP mode\*(  )

### Active clean function

The Active Clean Technology washes away dust, and mold that may cause odors when it adheres to the heat exchanger by automatically freezing and then rapidly thawing the frost. When this function is turned on, the indoor unit display window appears “CL”, after 20 to 130 minutes, the unit will turn off automatically and cancel CLEAN function.

### Sleep function( ) :

The SLEEP function is used to decrease energy use while you sleep (and don't need the same temperature settings to stay comfortable).

**NOTE:** The SLEEP function is not available in FAN and DRY mode.

### AP function( )(some units) :

Choose AP mode to do wireless network configuration. For some units, it doesn't work by pressing the SET button. To enter the AP mode, continuously press the LED button seven times in 10 seconds.

### Follow me function( ):

The FOLLOW ME function enables the remote control to measure the temperature at its current location and send this signal to the air conditioner every 3 minutes interval. When using AUTO, COOL or HEAT modes, measuring ambient temperature from the remote control (instead of from the indoor unit itself) will enable the air conditioner to optimize the temperature around you and ensure maximum comfort.

**NOTE:** Press and hold Cool/Heat Flash button for seven seconds to start/stop memory feature of Follow Me function.

- If the memory feature is activated, “ On ” displays for 3 seconds on the screen.
- If the memory feature is stopped, “ OF ” displays for 3 seconds on the screen.
- While the memory feature is activated, press the ON/OFF button, shift the mode or power failure will not cancel the Follow me function.

# App Setup And Operation

## Wireless control feature

### Applicable system: iOS, Android

- Please keep your APP up to date with the latest version.
- Due to special situation may be occurred, we explicitly claims below: Not all of the Android and iOS system are compatible with APP. We will not be responsible for any issue as a result of the incompatibility.

### Wireless safety strategy

- Smart kit only support WPA-PSK/WPA2-PSK encryption and none encryption. WPA-PSK/WPA2-PSK encryption is recommended.

## CAUTIONS:

- Due to different network situation, control process may return time-out sometimes. If this situation occurs, the display between board and APP maynot be the same, please do not feel confused.
- Smart Phone camera needs to be 5 million pixels or above to make sure scan QR code well.
- Due to different network situation, sometimes, request time-out could happen, thus, it is necessary to do network configuration again.
- The APP system is subject to update without prior notice for product function improvement.
- The actual network configuration process may be slightly different from the manual, the actual process shall prevail.
- Please check the Service Website for more information.

## SPECIFICATION:

- APP control module model: EU-SK110, US-SK110
- Antenna Type: Printed PCB Antenna
- Frequency Band: 2400-2483.5MHz
- Operation Temperature: 0°C~45°C/32°F~113°F
- Operation Humidity: 10%~85%
- Power Input: DC 5V/500mA
- Maximum TX Power: <20dBm

## PREPARATION

- Please ensure your mobile device is connected to wireless router. Also, the wireless router has already connected to Internet before doing user registration and network configuration.
- Make sure your mobile device has already been connected to the wireless network which you want to use. Also, you need to forget other irrelevant wireless network in case it influences your configuration process.

## Download and install app

1. Ensure the mobile phone is connected to your home network.
2. Scan the QR code or search for the MSmartHome application from the Google Play Store or Apple App Store on a smart device.



## Network configuration

### CAUTIONS:

- It is necessary to forget any other around network and make sure the Android or iOS device just connect to the wireless network you want to configure.
- Make sure the Android or iOS device wireless function works well and can be connected back to your original wireless network automatically.

### Kindly reminder:

- User must finish all the steps in 8 minutes after powering on air conditioner, otherwise you need to power on it again.

### NOTE:

- Make sure your devices are powered on.
- Keep your mobile phone close enough to your device when you are connecting network to your device.
- Connect your mobile phone to the wireless network at home, and make sure you know the password of the network.
- Check if your router supports 2.4 GHz wireless band and turn it on. If you are not sure whether the router supports 2.4 GHz band, please contact the router manufacturer.
- The device cannot connect to the wireless that requires authentication, and it usually appears in public area such as hotels, restaurants, etc. Please connect to a wireless network that does not require authentication.
- It is recommended to use a wireless network name that only contains letters and numbers.
- If your wireless network name contains special characters, please modify it in the router. Turn off the WLAN+ (Android) or WLAN Assistant (iOS) function of your mobile phone when connecting network to your devices.
- In the case that your device connected to wireless network before but it needs to reconnect, please click "+" on app Home page, and add your device again by the device category and model according to the instructions on app.

### Register and log in

Open the MSmartHome app, and create a new account to start ( you can also register through a third-party account). If you already had an existing account, use the account to log in.



## Connect your devices to MSmartHome

1. Please make sure your mobile phone is connected to wireless network. If not, go to Settings and turn on the wireless connection, select and connect to a wireless network. Also please turn on the Bluetooth on your phone. If not, go to Settings and turn it on.
2. Please power on your devices.
3. Open MSmartHome app on your phone.
4. If a message of "Smart devices discovered nearby" appears, click to add.

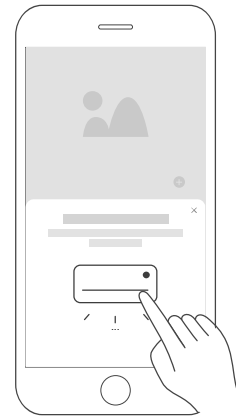

5. If no message appears, select "+" on the page and select your device in the list of nearby devices available. If your device is not listed, please add your device manually by the device category [Air Conditioner] and device model [Split AC].

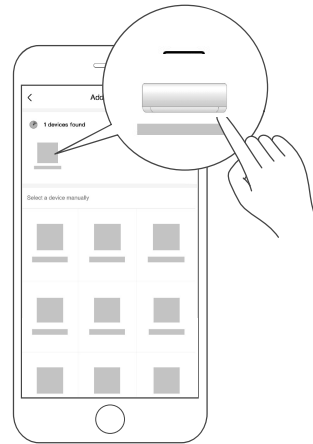

6. Connect your device to APP according to the instructions on app. If the connection fails, please follow the instructions provided by the app to continue with the operation.

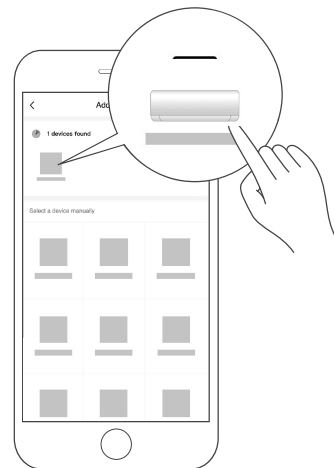

## How to use APP

Please ensure both your mobile device and air conditioner are connected to the Internet before using app to control the air conditioner via internet, please follow the steps:

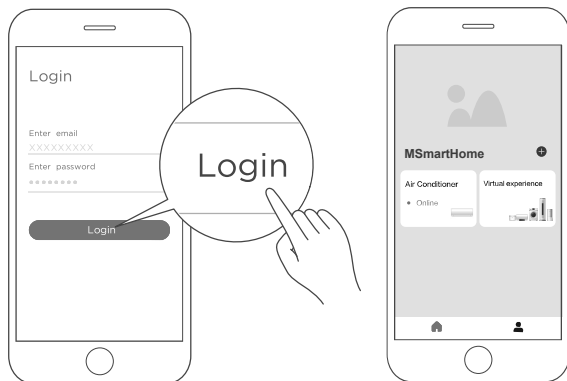

### NOTE:

Not all the function of the APP is available on air conditioner. For example: ECO, Boost, Swing function, please check the user manual to find more information.

1. Click "Login"

2. Choose the Air Conditioner.



3. Thus, user can control air conditioners on/off status, operation mode, temperature, fan speed and so on.

## Special functions

Including: Schedule, Sleep curve, Energy Monitor, Bill Control and Check.

**NOTE:** Not all the unit can use these special function on the APP. Thus, if the air conditioner do not support the above function, the function will be hidden from the function list.

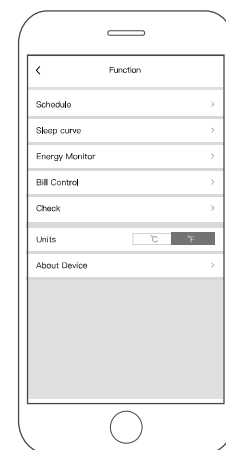

### Schedule

Weekly, user can make an appointment to turn on or off the air conditioner on specific time. User also can choose circulation to keep the air conditioner under schedule control every week.

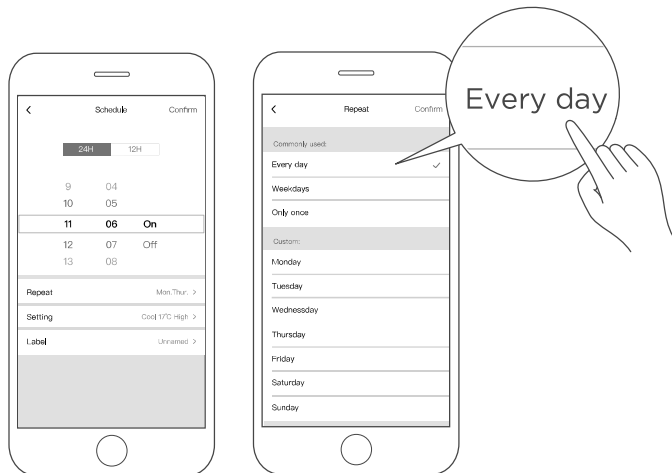

### Sleep

Users can customize their own comfortable sleep by setting target temperature.

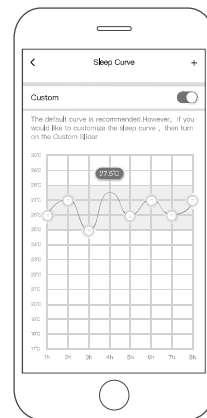

### Energy Monitor(Only for some units )

User can simply monitor the electricity consumption of air conditioner by checking the chart and history record.

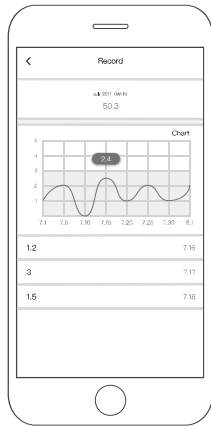
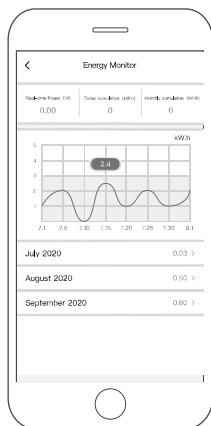

### Bill Control(Only for some units )

User can set parameters to limit the electricity consumption over a period of time.

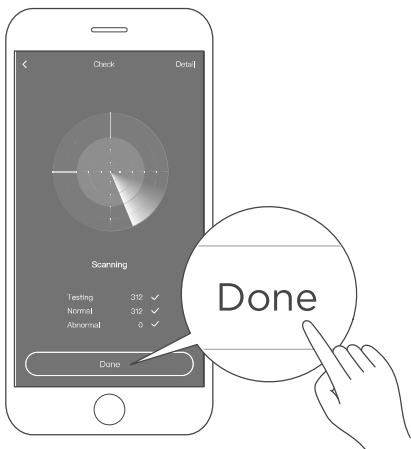
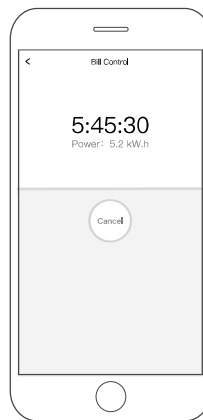

### Check

User can simply check the air conditioner running status with this function. When finishing this procedure, it can display the normal items, abnormal items, and detail information.

## APP DECLARATION

Hereby, we declare that this Smart kit is in compliance with the essential requirements and other relevant provisions of Directive 2014/53/EU. A copy of the full DoC is attached.  
(European Union products only)

### CAUTIONS:

**Wireless module models:** US-SK110,EU-SK110:

**FCC ID:** 2ADQOMDNA23

**IC:** 12575A-MDNA23

This device complies with Part 15 of the FCC Rules and it contains licence-exempt transmitter(s)/ receiver(s) that comply with Innovation, Science and Economic Development Canada's licence-exempt RSS(s).

#### Operation is subject to the following two conditions:

1. This device may not cause interference; and
2. This device must accept any interference, including interference that may cause undesired operation of the device.

Only operate the device in accordance with the instructions supplied. Changes or modifications to this unit not expressly approved by the party responsible for compliance could void the user's authority to operate the equipment. This device complies with FCC radiation exposure limits set forth for an uncontrolled environment. In order to avoid the possibility of exceeding the FCC radio frequency exposure limits, human proximity to the antenna shall not be less than 20cm (8 inches) during normal operation.

NOTE: This equipment has been tested and found to comply with the limits for a Class B digital device, pursuant to part 15 of the FCC Rules. These limits are designed to provide reasonable protection against harmful interference in a residential installation. This equipment generates, uses and can radiate radio frequency energy and, if not installed and used in accordance with the instructions, may cause harmful interference to radio communications. However, there is no guarantee that interference will not occur in a particular installation. If this equipment does cause harmful interference to radio or television reception, which can be determined by turning the equipment off and on, the user is encouraged to try to correct the interference by one or more of the following measures:

- Reorient or relocate the receiving antenna.
- Increase the separation between the equipment and receiver.
- Connect the equipment into an outlet on a circuit different from that to which the receiver is connected.
- Consult the dealer or an experienced radio/TV technician for help.



# CARE AND MAINTENANCE

## ⚠ CAUTION

- The cooling efficiency of your unit and your health would be damaged for the glogged AC, Make sure to clean the filter every two weeks.
- Always **TURN OFF** your AC system and disconnect its power supply before cleaning or maintenance.
- **Do not** touch air freshening (Plasma) filter at least 10 minutes after turning off the unit.
- Only use a soft, dry cloth to wipe the unit clean. You can use a cloth soaked in warm water to wipe it clean if the unit is especially dirty.
- Do not use chemicals or chemically treated cloths to clean the unit
- Do not use benzene, paint thinner, polishing powder or other solvents to clean the unit. They can cause the plastic surface to crack or deform.
- Do not use water hotter than 40°C (104°F) to clean the front panel. This can cause the panel to deform or become discolored.

## Cleaning Your Indoor Unit, Air Filter

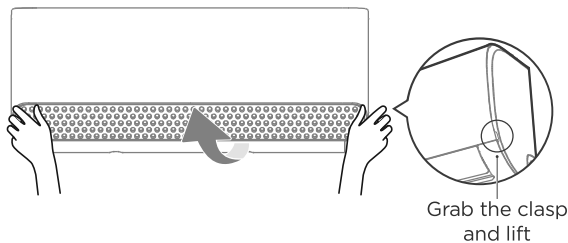

### Step 1:

Lift the front panel of the indoor unit.

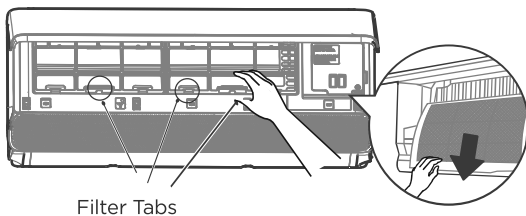

### Step 2:

Grip the tab on the end of the filter, lift it up, then pull it towards yourself and pull the filter out.

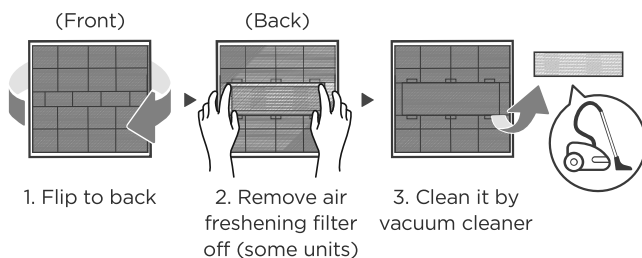

### Step 3:

If your filter has a small air freshening filter, unclip it from the larger filter. Clean this air freshening filter with a hand-held vacuum.

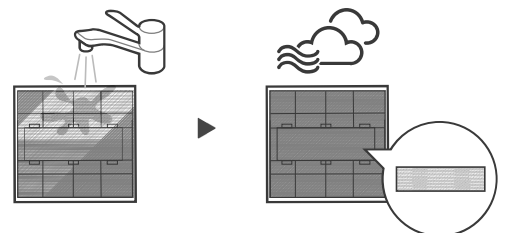

Don't forget to install me back

### Step 4:

Clean the large air filter with warm, soapy water. Be sure to use a mild detergent. Rinse the filter with fresh water, then shake off excess water. Dry it in a cool, dry place, and refrain from exposing it to direct sunlight.

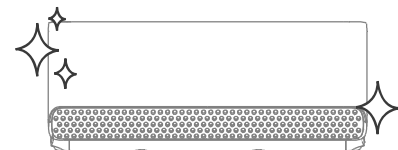

### Step 5:

When dry, re-clip the air freshening filter to the larger filter, then slide it back into the indoor unit. Finally, Close the front panel of the indoor unit.

## CAUTION

- Before changing the filter or cleaning, turn off the unit and disconnect its power supply.
- When removing filter, do not touch metal parts in the unit. The sharp metal edges can cut you.
- Do not use water to clean the inside of the indoor unit. This can destroy insulation and cause electrical shock.
- Do not expose filter to direct sunlight when drying. This can shrink the filter.
- Any maintenance and cleaning of outdoor unit should be performed by an authorized dealer or a licensed service provider.
- Any unit repairs should be performed by an authorized dealer or a licensed service provider.

## Air Filter Reminders (Optional)

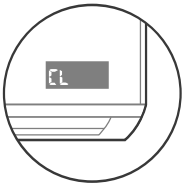

Display window: "CL"



Display window: "nF"

### Air Filter Cleaning Reminder

- After 240 hours of use, the display window on the indoor unit will flash "CL." This is a reminder to clean your filter. After 15 seconds, the unit will revert to its previous display.
- To reset the reminder, press the LED button on your remote control 4 times, or press the MANUAL CONTROL button 3 times. If you don't reset the reminder, the "CL" indicator will flash again when you restart the unit.

### Air Filter Replacement Reminder

- After 2,880 hours of use, the display window on the indoor unit will flash "nF." This is a reminder to replace your filter. After 15 seconds, the unit will revert to its previous display.
- To reset the reminder, press the LED button on your remote control 4 times, or press the MANUAL CONTROL button 3 times. If you don't reset the reminder, the "nF" indicator will flash again when you restart the unit.

## Maintenance your AC.

### Maintenance – Long Periods of Non-Use

If you plan not to use your air conditioner for an extended period of time, do the following:



Clean all filters



Turn on FAN function until unit dries out completely



Turn off the unit and disconnect the power

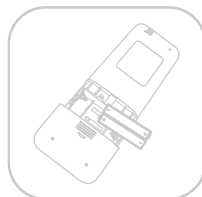

Remove batteries from remote control

### Maintenance – Pre-Season Inspection

After long periods of non-use, or before periods of frequent use, do the following:



Check for damaged wires

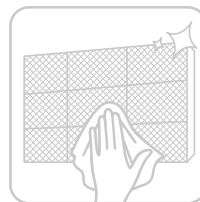

Clean all filters



Check for leaks



Make sure nothing is blocking all air inlets and outlets

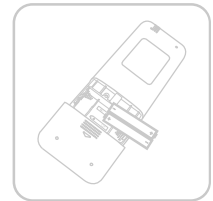

Replace batteries

# TROUBLESHOOTING

## CAUTION

If any of the following conditions occurs, turn off your unit immediately!

- The power cord is damaged or abnormally warm
- You smell a burning odor
- The unit emits loud or abnormal sounds
- A power fuse blows or the circuit breaker frequently trips
- Water or other objects fall into or out of the unit

**DO NOT ATTEMPT TO FIX THESE YOURSELF! CONTACT AN AUTHORIZED SERVICE PROVIDER IMMEDIATELY.**

## Common Issues

The following problems are not a malfunction and in most situations will not require repairs.

Issue	Possible Causes
<b>Unit does not turn on when pressing ON/OFF button</b>	The Unit has a 3-minute protection feature that prevents the unit from overloading. The unit cannot be restarted within three minutes of being turned off.
<b>The unit changes from COOL/HEAT mode to FAN mode</b>	<p>The unit may change its setting to prevent frost from forming on the unit. Once the temperature increases, the unit will start operating in the previously selected mode again.</p> <p>The set temperature has been reached, at which point the unit turns off the compressor. The unit will continue operating when the temperature fluctuates again.</p>
<b>The indoor unit emits white mist</b>	In humid regions, a large temperature difference between the room's air and the conditioned air can cause white mist.
<b>Both the indoor and outdoor units emit white mist</b>	When the unit restarts in HEAT mode after defrosting, white mist may be emitted due to moisture generated from the defrosting process.
<b>The indoor unit makes noises</b>	<p>A rushing air sound may occur when the louver resets its position.</p> <p>A squeaking sound may occur after running the unit in HEAT mode due to expansion and contraction of the unit's plastic parts.</p>
<b>Both the indoor unit and outdoor unit make noises</b>	<p>Low hissing sound during operation: This is normal and is caused by refrigerant gas flowing through both indoor and outdoor units.</p> <p>Low hissing sound when the system starts, has just stopped running, or is defrosting: This noise is normal and is caused by the refrigerant gas stopping or changing direction.</p> <p>Squeaking sound: Normal expansion and contraction of plastic and metal parts caused by temperature changes during operation can cause squeaking noises.</p>

Issue	Possible Causes
<b>The outdoor unit makes noises</b>	The unit will make different sounds based on its current operating mode.
<b>Dust is emitted from either the indoor or outdoor unit</b>	The unit may accumulate dust during extended periods of non-use, which will be emitted when the unit is turned on. This can be mitigated by covering the unit during long periods of inactivity.
<b>The unit emits a bad odor</b>	The unit may absorb odors from the environment (such as furniture, cooking, cigarettes, etc.) which will be emitted during operations.
	The unit's filters have become moldy and should be cleaned.
<b>The fan of the outdoor unit does not operate</b>	During operation, the fan speed is controlled to optimize product operation.
<b>Operation is erratic, unpredictable, or unit is unresponsive</b>	Interference from cell phone towers and remote boosters may cause the unit to malfunction. In this case, try the following: <ul style="list-style-type: none"> <li>• Disconnect the power, then reconnect.</li> <li>• Press ON/OFF button on remote control to restart operation.</li> </ul>

**NOTE:** If problem persists, contact a local dealer or your nearest customer service center. Provide them with a detailed description of the unit malfunction as well as your model number.

**⚠ CAUTION**

When troubles occur, please check the following points before contacting a repair company.

Problem	Possible Causes	Solution
<b>Poor Cooling Performance</b>	Temperature setting may be higher than ambient room temperature	Lower the temperature setting
	The heat exchanger on the indoor or outdoor unit is dirty	Clean the affected heat exchanger
	The air filter is dirty	Remove the filter and clean it according to instructions
	The air inlet or outlet of either unit is blocked	Turn the unit off, remove the obstruction and turn it back on
	Doors and windows are open	Make sure that all doors and windows are closed while operating the unit
	Excessive heat is generated by sunlight	Close windows and curtains during periods of high heat or bright sunshine
	Too many sources of heat in the room (people, computers, electronics, etc.)	Reduce amount of heat sources
	Low refrigerant due to leak or long-term use	Check for leaks, re-seal if necessary and top off refrigerant
SILENCE function is activated (optional function)	SILENCE function can lower product performance by reducing operating frequency. Turn off SILENCE function.	

Problem	Possible Causes	Solution
<b>The unit is not working</b>	Power failure	Wait for the power to be restored
	The power is turned off	Turn on the power
	The fuse is burned out	Replace the fuse
	Remote control batteries are dead	Replace batteries
	The Unit's 3-minute protection has been activated	Wait three minutes after restarting the unit
	Timer is activated	Turn timer off
<b>The unit starts and stops frequently</b>	There's too much or too little refrigerant in the system	Check for leaks and recharge the system with refrigerant.
	Incompressible gas or moisture has entered the system.	Evacuate and recharge the system with refrigerant
	The compressor is broken	Replace the compressor
	The voltage is too high or too low	Install a manostat to regulate the voltage
<b>Poor heating performance</b>	The outdoor temperature is extremely low	Use auxiliary heating device
	Cold air is entering through doors and windows	Make sure that all doors and windows are closed during use
	Low refrigerant due to leak or long-term use	Check for leaks, re-seal if necessary and top off refrigerant
<b>Indicator lamps continue flashing</b>	<p>The unit may stop operation or continue to run safely. If the indicator lamps continue to flash or error codes appear, wait for about 10 minutes. The problem may resolve itself.</p> <p>If not, disconnect the power, then connect it again. Turn the unit on.</p> <p>If the problem persists, disconnect the power and contact your nearest customer service center.</p>	
<p><b>Error code appears and begins with the letters as the following in the window display of indoor unit:</b></p> <ul style="list-style-type: none"> <li>• E(x), P(x), F(x)</li> <li>• EH(xx), EL(xx), EC(xx)</li> <li>• PH(xx), PL(xx), PC(xx)</li> </ul>		

**NOTE:** If your problem persists after performing the checks and diagnostics above, turn off your unit immediately and contact an authorized service center.

# TRADEMARKS, COPYRIGHTS AND LEGAL STATEMENT

 Midea logo, word marks, trade name, trade dress and all versions thereof are valuable assets of Midea Group and/or its affiliates (“Midea”), to which Midea owns trademarks, copyrights and other intellectual property rights, and all goodwill derived from using any part of an Midea trademark. Use of Midea trademark for commercial purposes without the prior written consent of Midea may constitute trademark infringement or unfair competition in violation of relevant laws.

This manual is created by Midea and Midea reserves all copyrights thereof. No entity or individual may use, duplicate, modify, distribute in whole or in part this manual, or bundle or sell with other products without the prior written consent of Midea.

All the described functions and instructions were up to date at the time of printing this manual. However, the actual product may vary due to improved functions and designs.

## DISPOSAL AND RECYCLING

### **Important instructions for environment(European Disposal Guidelines)**

Compliance with the WEEE Directive and Disposing of the Waster Product:  
This product complies with EU WEEE Directive (2012/19/EU). This product bears a classification symbol for waster electrical and electronic equipment (WEEE).

This symbol indicates that this product shall not be disposed with other household wastes at the end of its service life. Used device must be returned to official collection point for recycling of electrical electronic devices. To find these collection systems please contact to your local authorities or retailer where the product was purchased. Each household performs important role in recovering and recycling of old appliance. Appropriate disposal of used appliance helps prevent potential negative consequences for the environment and human health.



# DATA PROTECTION NOTICE

For the provision of the services agreed with the customer, we agree to comply without restriction with all stipulations of applicable data protection law, in line with agreed countries within which services to the customer will be delivered, as well as, where applicable, the EU General Data Protection Regulation (GDPR).

Generally, our data processing is to fulfil our obligation under contract with you and for product safety reasons, to safeguard your rights in connection with warranty and product registration questions. In some cases, but only if appropriate data protection is ensured, personal data might be transferred to recipients located outside of the European Economic Area.

Further information are provided on request. You can contact our Data Protection Officer via **MideaDPO@midea.com**. To exercise your rights such as right to object your personal data being processed for direct marketing purposes, please contact us via **MideaDPO@midea.com**. To find further information, please follow the QR Code.

The design and specifications are subject to change without prior notice for product improvement. Consult with the sales agency or manufacturer for details. Any updates to the manual will be uploaded to the service website, please check for the latest version.

Importer: Frigo-kor d.o.o Majstorska 11 10000 Zagreb Croatia  
Manufacturer: GD Midea Air-Conditioning Equipment Co,.Ltd.  
Lingang Road Beijiao Shunde Foshan Guangdong  
People's Republic of China 528311



[www.midea.com](http://www.midea.com)  
© Midea 2022 all rights reserved

CS021UI-CB(OBM)  
16122000A73580